

NOTE

This copy of the Procedure Manual (CET-QMS-MANUAL-P, 2nd Edition, Issue Status-2) is a controlled version. It does not contain signature. Original signed Master Copy, in hard form, is available with Business Excellence Section.

This Procedure Manual is effective from 26th September, 2024.

ISO 9001: 2015
QUALITY MANAGEMENT SYSTEM

CET PROCEDURES MANUAL
2nd EDITION
(Issue status: 2)



STEEL AUTHORITY OF INDIA LIMITED
CENTRE FOR ENGINEERING & TECHNOLOGY
(In-house Engineering & Technology Consultant)
RANCHI - 834002

Original : 05 March 2022
2nd Revision : 26 September 2024

CET-QMS-MANUAL-P

FOREWORD

Centre for Engineering and Technology (CET) has been progressively growing since its inception in 1983. In pursuit of excellence and for providing quality services of International Standards to customers, CET's endeavor has always been to strengthen the existing areas of excellence and identify new areas of activities.

Since the date of first certification on 25th May, 1994, CET has been successfully maintaining its Quality Management System (QMS) certified under ISO 9001 standard.

Procedure Manual (Edition 2, Issue Status 1), based on ISO 9001:2015 QMS, has been reviewed for incorporation of required modifications emerging out of continual improvement measures/ experience gained during day-to-day working/ mitigating audits observations/ compliance of directives/ guidelines from CO-SAIL/ MoS-GoI, Implementation of EDDMS (digiCET) etc. Accordingly, Procedures for TER and change order have been reviewed and modified in the present Procedure Manual (Edition 2, Issue Status 2).

It is imperative that we follow the procedures and various provisions of QMS religiously to bring uniformity in our approach and strive for achieving customer satisfaction, customer delight and finally customer loyalty.

Ranchi
26.09.2024

(Shrawan Kumar Verma)
Executive Director(CET)

TABLE OF CONTENTS

Sl. No.	Chapter no./ Procedure no.	Title of Chapter / Procedure	Issue Status	Date of Issue	Nos. of Pages
		Cover Page	2	26.09.2024	1
A.	Chapter A	Foreword	1	26.09.2024	1
B.	Chapter B	Table of Contents	2	26.09.2024	2
	Chapter C	Important notes	0	05.03.2022	2
C.	Chapter D	Edition Status	2	26.09.2024	1
D.	Chapter E	List of formats	1	05.09.2024	1
E.	Chapter F	Explanation of abbreviations	1	05.09.2024	2
E.	Chapter G	Important vocabulary as per ISO 9000	0	05.03.2022	2
1.	P 7.5-01	Modification/ addition of procedures	0	05.03.2022	3
2.	P 7.5-02	Control of documents and records	0	05.03.2022	2
3.	P 7.5-03	Control of BIS codes	0	05.03.2022	1
4.	P 9.3-04	Management review of QMS	0	05.03.2022	2
5.	P 7.2-05	Training of personnel	0	05.03.2022	2
6.	P 7.2-06	Authorization of personnel	0	05.03.2022	3
7.	P 8.2-07	Acceptance/Non-acceptance of assignment	1	05.09.2024	6
8.	P 8.2-08	Checking/ approval of contractor's drawings and documents	0	05.03.2022	4
9.	P 8.3-09	Design	0	05.03.2022	5
10.	P 8.3-10	Design validation	0	05.03.2022	2
11.	P 8.3-11	Preparation & Approval of FR, AN, Scheme, Study Report & DPR	1	05.09.2024	5
12.	P 8.3-12	Preparation & approval of TS (For single & multiple packages), Technical Note, Tender Document, Expression of Interest	1	05.09.2024	6
13.	P 8.3-13	Preparation & approval of OS	0	05.03.2022	3
14.	P 8.3-14	Preparation & approval of MNP	0	05.03.2022	3
15.	P 8.3-15	Preparation & approval of Draft Investment Proposal (DIP)	1	05.09.2024	2
16.	P 8.3-16	Evaluation of bid (Technical part)	1	26.09.2024	2
17.	P 8.3-17	Price bid evaluation	0	05.03.2022	1
18.	P 8.3-18	Preparation of drawings	0	05.03.2022	9
19.	P 8.3-19	Checking and approval of drawings	0	05.03.2022	2
20.	P 8.3-20	Revision of drawings	0	05.03.2022	2
21.	P 8.4-21	Recommending suppliers for issue of Limited Tender Enquiry (LTE)	0	05.03.2022	5
22.	P 8.3-22	Internal assignments	0	05.03.2022	3
23.	P 8.5-23	Review of assignments	0	05.03.2022	3
24.	P 8.5-24	Customer supplied products	0	05.03.2022	2
25.	P 9.1-25	Internal audit of QMS	0	05.03.2022	3
26.	P 9.1-26	Customer Satisfaction Index (CSI)	0	05.03.2022	2
27.	P 8.7-27	Customer complaints and corrective actions for non-conformities	0	05.03.2022	3



Sl. No.	Chapter no./ Procedure no.	Title of Chapter / Procedure	Issue Status	Date of Issue	Nos. of Pages
28.	P 10.2-28	Preventive actions	0	05.03.2022	2
29.	P 8.5-29	Contract signing	0	05.03.2022	2
30.	P 8.5-30	Processing of Change Order	1	26.09.2024	16
31.	P 8.5-31	Preparation & approval of Eligibility Criteria (EC)	0	05.09.2024	2
32.	P 8.5-32	Preparation & approval of Capital Cost Estimate (CE)	0	05.09.2024	2
33.	P 8.5-33	Preparation & approval of Package Cost	0	05.09.2024	2

IMPORTANT NOTES

1. CET Procedures Manual is a confidential document for internal circulation and shall be used for Quality Management System (QMS) of Centre for Engineering & Technology (CET). It shall neither be reproduced in any form nor used for any other purpose except with the written permission from Management Representative (MR) of CET, Ranchi.
2. Provisions given in this manual will supersede those given in any other document/ manual in circulation in CET.
3. In case of revision of the existing edition of the manual, the changes in this manual are highlighted in bold and italics. The letters will be normal in case of new edition of manual. The issue status of chapters will be '0' in case of new edition of manual. The issue status subsequently will be 1, 2 etc. for each revision of the existing edition. While making a new edition (In case of many changes in the manual), issue status will again be '0' for the new edition number.
4. System of numbering of procedures in CET Procedures Manual is as follows:

P X.X-YY

Explanation:

- | | | |
|-----|---|---------------------------------------|
| P | - | Procedure |
| X.X | - | Applicable clause no. |
| YY | - | Serial no. of procedure in two digits |

IMPORTANT NOTES

1. Important verbal communications from customers shall be recorded and acknowledged, if required.
2. Obsolete documents/ drawings (if retained in CET) shall be marked as 'SUPERSEDED'.
3. Whenever corrigendum/ addendum are issued for any document the original document shall be suitably cross-referenced. A copy of corrigendum/ addendum shall be kept with the main document.
4. Decisions taken in Steering Committee/ Management Review Meetings from time to time shall also be applicable over and above the provisions given in various procedures.
5. All documents and records can be stored in hard/ soft copy. Transmission can also be done in hard/ soft copy.
6. In case of soft copy being transmitted through e-mail or uploaded electronically, signature is not necessary.

Edition Status

(CET's Procedure Manual based on ISO 9001:2015 QMS)

EDITION & ISSUE STATUS	DATE OF EDITION	DESCRIPTION OF CHANGES IN CHAPTER/ PARA
EDITION-02, ISSUE-0	05.03.2022	New edition
EDITION-02, ISSUE-1	05.09.2024	Modification in 4 existing procedures (No. 7, 11, 12, 15 and addition of 3 new procedures 31, 32 & 33)
EDITION-02, ISSUE-2	26.09.2024	Modification in existing procedures (No. 16: for Bid evaluation and 30: for Change order)

LIST OF FORMATS

Sl. No.	Format no.	Title of Format	Annexed with Procedure no.
1.	CET-GEN-01	Request for developing new procedures/ chapters or modifying existing procedures/ chapters	P 7.5-01
2.	CET-GEN-02	Record for customer supplied products	P 8.5-24
3.	CET-GEN-03	Drawing register	P 8.3-18
4.	CET-GEN-04	Internal assignment	P 8.3-22
5.	CET-GEN-05	Verification of OS	P 8.3-13
6.	CET-GEN-06	Design sheet	P 8.3-09
7.	CET-GEN-07	Design summary sheet	P 8.3-09
8.	CET-GEN-08	Record of design validation	P 8.3-10
9.	CET-GEN-09	Verification of TS	P 8.3-12
10.	CET-GEN-10	Verification of MNP	P 8.3-14
11.	CET-GEN-11	Activity planning schedule	P 8.3-11
12.	CET-GEN-12	Internal Audit (IA) of CET's QMS	P 9.1-25
13.	CET-PFC-01	Requisition/ approval for "Acceptance of assignment".	P 8.2-07
14.	CET-PFC-03	Assignment review record	P 8.5-23
15.	CET-PFC-04	Customer complaint and non-conformity record	P 8.7-27
16.	CET-PFC-05	Customer feedback	P 9.1-26

EXPLANATION OF ABBREVIATIONS

ABBREVIATION	EXPLANATION
Adm. Officer	Administering Officer
AN	Approach Note
BER	Basic Engineering Report
BE	Business Excellence
BIS	Bureau of Indian Standards
C & C	Contracts & Commercial
CET	Centre for Engineering & Technology
CGM	Chief General Manager
CGM(PL)	Chief General Manager of the section of Package Leader
CGM (LS)	Chief General Manager of Lead Section
C & IT	Computer & Information Technology
Cl. No.	Clause Number
CSI	Customer Satisfaction Index
CTE	Cost & Techno-Economics
DC	Draft Contract
DE	Detailed Engineering
Dept.	Department
DGM	Deputy General Manager
DIP	Draft Investment Proposal
DO	Desk Officer
Docs	Documents
DPR	Detailed Project Report
Drgs	Drawings
DS	Designer's Supervision
ED	Executive Director
e-Docman/SAN	e-Documents/Storage Area Network
EOI	Expression of Interest
FR	Feasibility Report
GM	General Manager
HOD	Head of Department
HOD (SC)	Head of Sub-Centre
HOD (LS)	Head of Department of Lead Section
HOD (PL)	Head of Department of Package Leader
IBM	Indian Bureau of Mines
I/c	In-charge
IA	Internal Auditor
IPSS	Inter-Plant Standardisation in Steel Industry
IS	Indian Standard

ABBREVIATION	EXPLANATION
ISO	International Organisation for Standardisation
ITT	Invitation to Tender
MAN	Manual
Mgr	Manager
MNP	Mining Plan
MOM	Minutes of Meeting
MP	Master Plan
MR	Management Representative
NCR	Non-Conformity Report
NIT	Notice Inviting Tenders
OS	Ordering Specification
P & A	Personnel & Administration
PCA	Post Commissioning Assistance
PC & A	Process Control and Automation
PCR	Project Completion Report
PFC	Project Formulation & Co-ordination
PFR	Pre-Feasibility Report
PL	Package Leader
PMS	Project Monitoring System
QMS	Quality Management System
QAP	Quality Assurance Plan
QP	Qualified persons responsible to prepare MNP
RDCIS	Research & Development Centre for Iron & Steel
RND	Record Notes of Discussion
SAIL	Steel Authority of India Limited
SC	Scheme
SR	Study Report
TD	Tender Document
TER	Technical Evaluation Report
TF	Task Force
TFL	Task Force Leader
TFM	Task Force Member
TN	Technical Note
TQP	Total Quality Process
Trg	Training
TS	Tender Specification
w.r.t.	with respect to

IMPORTANT VOCABULARY AS PER ISO 9000

Quality	Degree to which a set of inherent characteristics fulfills requirements
Organization	Group of people and facilities with an arrangement of responsibilities, authorities and relationship
Customer	Organization or person that receives a product
Supplier	Organization or person that provides a product
Process	Set of interrelated or interacting activities which transforms inputs into outputs
Product	Result of a process. There are four generic product categories: (1) Services (2) Software (both are generally intangible) (3) Hardware (4) Processed materials (both are tangible)
System	Set of interrelated or interacting elements
Quality Management	Coordinated activities to direct and control an organization with regard to quality
Quality Management System	Management system to direct and control an organization with regard to quality
Quality Planning	Part of quality management focused on setting quality objectives and specifying necessary operational processes and related resources to fulfill the quality objectives
Quality Plan	Document specifying which procedures and associated resources shall be applied by whom and when to a specific project, product, process or contract
Quality Policy	Overall intentions and direction of an organization related to quality as formally expressed by top management.
Quality improvement	Part of quality management focused on increasing the ability to fulfill quality requirements
Continual improvement	Recurring activity to increase the ability to fulfill requirements
Design and development	Set of processes that transform requirements into specified characteristics or into the specification of a product, process or system
Verification	Conformation, through the provision of objective evidence, that specified requirements have been fulfilled.
Validation	Conformation, through the provision of objective evidence, that the requirements for a specific intended use or application have been fulfilled.
Review	Activity undertaken to determine the suitability, adequacy and effectiveness of the subject matter to achieve established



	objectives.
Audit	Systematic, independent and documented process for obtaining audit evidence and evaluating it objectively to determine the extent to which audit criteria are fulfilled.
Non-conformity	Non fulfillment of a requirement.
Corrective action	Action to eliminate the cause of a detected non-conformity or other undesirable situation.
Preventive action	Action to eliminate the cause of a potential non-conformity or other undesirable potential situation.
Customer satisfaction	Customer's perception of the degree to which the customer's requirements have been fulfilled.

All other vocabulary applicable for QMS of CET is as per ISO 9001.

1. **Title:** Modification/ addition of procedures
2. **Purpose:** To continually update CET Quality & Procedures Manuals
3. **Scope:** CET Quality Manual and CET Procedures Manuals
4. **Overall responsibility:** MR
5. **Details of sequential activities:**

Sl. No.	Description	Responsibility
A.	Identify whether new procedure is to be developed or existing procedure to be modified based on any of the following: i) Suggestions from employees as per format no. CET-GEN-01 ii) Revision of ISO 9001 standard iii) Any other source	BE co-ordinator
B.	Analyse the suggestion with MR and decide course of action. If needed, make an action plan.	BE co-ordinator
C.	i) Send acknowledgement to sender, if received suggestion ii) Act as per the decided action plan. In case of a new procedure, form a core group in consultation with MR and with approval from ED.	BE co-ordinator
D.	Analyze the draft received from the core group/ suggestions received/ proposed draft revision, Put up to Chairman, Approval Committee after obtaining clearance from members of approval committee.	BE co-ordinator
E.	Get clearance from Chairman, Approval Committee. <u>Note :</u> i) In case of issue of new editions of manuals, all procedures and chapters will be signed by ED. ii) In case of modification/ addition of procedures, it will be signed by Chairman, Approval Committee.	BE co-ordinator
F.	Obtain recommendation of MR.	BE co-ordinator
G.	Obtain approval of ED, CET.	BE co-ordinator
H.	Upload the controlled soft copy of the manual in CET portal.	BE co-ordinator/ HOD (C & IT)
I	Keep the master hard copy of the manual signed by MR and ED, CET in safe custody in BE.	BE co-ordinator



Sl. No.	Description	Responsibility
	Records to be maintained	
i.	Master copy of approved procedures	BE co-ordinator

ISSUED & CONTROLLED BY

APPROVED

(MANAGEMENT
REPRESENTATIVE)

(EXECUTIVE DIRECTOR)

Format no. CET-GEN-01
(Reference Procedure no. P 7.5-01)

SUGGESTION FOR MODIFICATION/ ADDITION OF PROCEDURES

1. Suggestion for (please tick appropriate box)
 - A. Incorporation of new procedure
 - B. Modification of existing procedure
2. In case of new procedure title and details of procedure
3. In case of modification, details of the modification
4. Justification for new procedure or modification of existing procedure:
(Give as much details as possible. Add separate sheet, if required)

5. Enclosures (if any):

Signature:

Name:

Designation:

Department/ Sub-Centre

Date:

BE co-ordinator



- 1. Title:** Control of documents and records
- 2. Purpose:** Control of all documents & records related to QMS.
- 3. Scope:** Documents and records mentioned below
- 4. Overall responsibility:** MR
- 5. Details of sequential activities:**

Sl. No.	Description	Responsibility
A.	<p>Maintain following properly identified and legible documents:</p> <p>Approved CET Quality Manual, CET Procedures Manual, Context of the Organization, Needs & expectations of interested parties, Opportunities & action plan and Risk assessment & contingency plan in CET Portal.</p> <p>Follow Procedure no. P 7.5-01 of CET Procedures Manual for:</p> <ul style="list-style-type: none"> i) Approval of documents for adequacy prior to issue ii) Revision/ modification/ addition of above iii) Preparation and issue of controlled copy iv) Ensuring that changes and the current revision status of documents are identified v) Ensuring that the relevant versions of applicable documents are available at point of use vi) Identifying & controlling the distribution of necessary documents of external origin- vii) Prevention of unintended use of obsolete documents. 	
		BE Co-ordinator/ HOD (C & IT)
B.	<p>Maintain following properly identified and legible records:</p> <ul style="list-style-type: none"> i) Steering Committee/ Management Review Meeting records ii) Qualification and training records of employees iii) Acceptance of assignments records in format no. CET-PFC-01 iv) Design summary sheets in format no. CET-GEN-07 v) Records of presentation (design review) and approval of reports vi) Records of verification of MNP, TS and OS in proper formats 	MR
		In-charge (Concerned Deptt.)
		In-charge (PFC)
		Engineer concerned
		In-charge (PFC)
		HOD (LS)



Sl. No.	Description	Responsibility
	vii) Assignment review records in CET-PFC-03	HOD (LS)
	viii) Design validation records	HOD (LS)
	ix) Internal Audit reports (summary)	MR
	x) Customer complaints and non-conformity record in format no. CET-PFC-04	In-charge (PFC) & HOD (SC)
	xi) Preventive actions taken for non-conformities.	MR
	xii) Records of customer feedback in format no. CET-PFC-05	In-charge (PFC)
C.	Maintain records for at least three years in relevant files as per relevant procedures and store back up in a safe place for protection and quick retrieval.	HODs
D.	Dispose the records by shredding/ deleting after the retention period.	As given above
	Records to be maintained	
i.	Documents and records as listed above	As given above

ISSUED & CONTROLLED BY

APPROVED

**(MANAGEMENT
REPRESENTATIVE)**

(EXECUTIVE DIRECTOR)



1. **Title:** Control of BIS codes
2. **Purpose:** To ensure availability of the latest BIS codes
3. **Scope:** IS codes used in CET
4. **Overall responsibility:** I/c Business Excellence
5. **Details of sequential activities:**

Sl. No.	Description	Responsibility
A.	Updating of BIS Codes	I/c Business Excellence
	Renew the contract for updating the BIS standards each year and get the updated standard from the vendor as per contract	
Records to be maintained		
i.	Copy of contract with vendor	I/c Business Excellence
ii.	Records of updating BIS by the vendor	I/c Business Excellence

ISSUED & CONTROLLED BY

APPROVED

**(MANAGEMENT
REPRESENTATIVE)**

(EXECUTIVE DIRECTOR)

1. **Title:** Management review of QMS
2. **Purpose:** To ensure continuing suitability, adequacy and effectiveness of QMS
3. **Scope:** All documents under QMS
4. **Overall responsibility:** MR
5. **Details of sequential activities:**

Sl. No.	Description	Responsibility
A.	Collect all relevant data of Quality Management System. Analyse the data and prepare tables/ graphs etc. for consideration of Steering Committee.	BE co-ordinator
B.	Organise Steering Committee Meeting with permission from ED for management review, at least once in a year. Submit report to ED on QMS for consideration during management review.	MR
C.	Review the following: i) Findings of audits ii) Customer complaints received since last review iii) Customer satisfaction index iv) Status of corrective and preventive actions v) Follow up actions of previous management reviews vi) Status & effectiveness of implementation of the QMS w.r.t objectives vii) Improvement activities viii) Review of Quality Policy, if required	Steering Committee
D.	Finalise action plans for the following, as required: i) Improvement of the effectiveness of QMS ii) Improvement in quality of documents and drawings iii) Resources needed	Steering Committee
E.	Prepare record notes of Steering Committee Meeting and circulate to all concerned for necessary actions	BE co-ordinator
F.	If necessary, discuss and follow up the actions with individuals concerned	MR/ BE co-ordinator



Records to be maintained		
i.	Report on QMS	BE co-ordinator
ii	Agenda and record notes of Steering Committee Meeting	BE co-ordinator

ISSUED & CONTROLLED BY

APPROVED

(MANAGEMENT
REPRESENTATIVE)

(EXECUTIVE DIRECTOR)

1. **Title:** Training of personnel
2. **Purpose:** To identify training need, provide training and ascertain effectiveness of training on performance level
3. **Scope:** All employees upto E5 level
Specific recommendations for executives of E6 and above grade (for providing training only)
Note:
 - i) Training of Management Trainees of CET is jointly provided by one of the SAIL plants and CET.
 - ii) Training needs of executives in E6 and above grade is generally fulfilled by Management Training Institute (MTI), Ranchi
4. **Overall responsibility:** I/c (Training)
5. **Details of sequential activities:**

Sl. No.	Description	Responsibility
A.	Identify training needs: i) Based on training needs (through on line Performance Management System) for executives up to E5 level ii) Based on assessment done by HOD for non-executives	I/c (Training)
B.	Finalise training needs in consultation with HOD and previous experience/ feedback.	I/c (Training)
C.	Make a training plan based on steps A, B and organisational training needs and get approved by Training Advisory Committee (TAC).	I/c (Training)
D.	Nominate employees based on steps - A, B & C or specific recommendations with the approval of ED.	I/c (Training)
E.	Design training programs, if required, in consultation with HODs, wherever standard modules are not available.	I/c (Training)



F.	Identify faculty with approval of ED and assign course co-ordinator for the training programs conducted by CET.	I/c (Training)
G.	Make all arrangements for conducting the training.	I/c (Training)
H.	Conduct the training program.	Course co-ordinator
I.	Get feedback at the end of the training.	Course co-ordinator
J.	Take corrective measures for future training programmes.	I/c (Training)
K.	If required, nominate employees for seminar/ workshop/ conference etc. for need fulfillment, with consent of HOD and after getting approval from ED.	I/c (Training)
L.	Send format to HOD(s) for ascertaining effectiveness of training on performance level, within three to six months after the date of training.	I/c (Training)
M.	Send filled up format for effectiveness to In-charge (Training)	HOD
N.	In case, the training is found not effective for an employee, then it shall be referred to Training Advisory Committee.	In-charge (Training)
Records to be maintained		
i.	Training needs	In-charge (Training)
ii.	Training plan	In-charge (Training)
iii.	Training conducted	In-charge (Training)
iv.	Record of effectiveness of training	In-charge (Training)

ISSUED & CONTROLLED BY

APPROVED

**(MANAGEMENT
REPRESENTATIVE)**

(EXECUTIVE DIRECTOR)



1. **Title:** Authorisation of personnel
2. **Purpose:** To authorize competent personnel for design, checking and approval of design
3. **Scope:** All technical executives of CET
4. **Overall responsibility:** I/c (P&A)
5. **Details of sequential activities:**

Sl. No.	Description	Responsibility
A.	<p>Identify the area(s) in which the individual will carry out design, engineering and consultancy work by considering the following and recommend for authorisation (refer Annex):</p> <ul style="list-style-type: none"> i) Educational qualification ii) Previous training iii) Experience iv) On the job attachment training <p>Note: Executives joining CET from outside SAIL, who do not have work experience in design area, are required to undergo attachment training for a minimum period of six (6) months, to get familiarized with working of CET.</p>	HOD
B.	Organise attachment training of individual(s), if required, in consultation with HOD.	In-charge (Training)
C.	Review design experience acquired by individual(s) after the stipulated period of attachment training as per step - B and send recommendation to CGM for approval	HOD
D.	Send approved recommendation for authorization of individual(s) to I/c P&A	CGM
E.	Authorize individual(s) to carry out specific activities of his area and intimate HOD.	I/c(P&A)
F.	Review authorization record of personnel in department carrying out specific activities annually or as per requirement whichever is earlier and follow the procedure from step C onwards.	HOD



	Records to be maintained	
i.	Authorization of personnel in the Department/ Sub-Centre	HOD
ii.	Records of education, training and experience	I/c(P&A)

ISSUED & CONTROLLED BY

APPROVED

**(MANAGEMENT
REPRESENTATIVE)**

(EXECUTIVE DIRECTOR)

Annex

(Reference procedure no. P 7.2-06)

MINIMUM CRITERIA FOR AUTHORISATION
FOR DESIGN, ENGINEERING & CONSULTANCY WORK

1. Educational Qualification:
Bachelor's degree in engineering or equivalent (as recognized by SAIL)
2. Training:
 - i) One year on-the-job training in any plant/ unit of SAIL or in any similar concern other than SAIL.
 - ii) Minimum six months job attachment training in CET if the person does not have design work experience in relevant area.
3. Design Experience:
 - i) Minimum six months on-the-job experience of relevant area in SAIL or in similar organisation for being authorised to DESIGN.
 - ii) Minimum one year on the job experience of relevant area in SAIL or in similar organisation for being authorised to CHECK.
 - iii) Minimum one year on the job experience of relevant area in SAIL or in similar organisation for being authorised to approve, in case of executives in E5 and above.
 - iv) Minimum three years on the job experience of relevant area in SAIL or in similar organisation or as per discretion of HOD, for authorisation of approval in case of executives E4 and below.

1. **Title:** Acceptance / Non acceptance of assignment
2. **Purpose:** To ensure that customer's needs have been fully understood and acceptance/ non-acceptance is communicated to customer in stipulated time
3. **Scope:** All assignments received from customers
4. **Overall responsibility:** In-charge (PFC)
5. **Details of sequential activities:**

Sl. No.	Description	Responsibility
A.	Upload a scanned copy of the new assignment request letter received from customer in the PMS/digiCET through the tab for "New Assignment Request" under the heading "New Assignment". If there is no Sub-Centre, new assignment request letter will be received and uploaded by In-charge (PFC) in the PMS/digiCET	In-charge (SC)/ In-charge (PFC)
B.	<p>i) Send & upload interim reply/ acknowledgement to the customer in the PMS/digiCET within five days from the date of receipt of letter by Sub-Centre.</p> <hr/> <p>ii) If there is no Sub-Centre, interim reply/acknowledgement will be sent directly to customer and uploaded in PMS/digiCET by Project-PFC within 5 days.</p> <hr/> <p>iii) In the PMS/digiCET, upload observations of Sub-Centre (after site visit/ discussion), preferably within 10 days from the date of receipt of client letter.</p> <p>iv) The Sub-Centre feedback will be regarding acceptability of assignments and whether Sub-Centre can take up as lead section or not.</p> <p>v) Communicate the client letter along with Sub Centre feedback to concerned In-charges and probable lead section for their observation.</p> <hr/> <p>vi) Discuss customer's request alongwith observations as above in ED's review meeting and get decision on acceptance/ non-acceptance, lead section etc.</p> <hr/> <p>vii) If assignment is acceptable and deliverable is FR,</p>	<p>In-charge (SC)</p> <hr/> <p>In-charge (PFC)</p> <hr/> <p>In-charge (SC)</p> <hr/> <p>In-charge (PFC)</p> <hr/> <p>In-charge(LS)</p>



	<p><i>select the strategy to be adopted for preparation of FR i.e. FR with capital cost (projects in which scope is not very large and CET has past reference of such projects) or FR with block cost (initially) (projects in which scope is diverse and involves multiple agencies and requires in depth deliberation with plant to finalize scope.)</i></p> <hr/> <p>viii) Prepare & upload the RND of decision in PMS/digiCET for communication to concerned In-charges.</p> <p>ix) Upload a copy of the acceptance letter in the PMS/digiCET. Communicate the acceptance to the customer through In-charge(SC).</p> <p>x) Communicate directly to the customer where there is no sub-center. In case of non-acceptance, intimate the same to the customer through In-charge(SC)/ directly, if there is no Sub-Centre.</p>	In-charge (PFC)
C.	Collect all information; fill up format CET-PFC-01 (along with Activity Planning in format no. CET-GEN-11) in PMS/digiCET. Enter details of all TFMs and engg. hrs in the PMS/digiCET, within 7 days from the date of new assignment meeting.	In-charge (LS)/ In-charges concerned
D.	Obtain approval of PFC-01 from CGM (Projects). Send submission schedule to customer through In-charge (SC)/ directly, if there is no Sub-Centre. Send a copy of the submission schedule to all concerned. <i>Communication of submission schedule to include name of “Lead section”, “In-charge Lead section” and “TFL”.</i>	In-charge (PFC)
E.	<i>In case of change in scope/ schedule, title/ others and change in Lead section/TFL, inform client through Sub-centres</i>	DO
6.	Monitoring activities	Responsibility
A.	Monitor response time for acceptance/ non-acceptance of assignment. Note: i) Interim reply shall be sent within five (5) days from the date of receipt in Sub-Centre /Projects PFC. ii) Communication regarding acceptance/ non-	In-charge (PFC)



	acceptance to be sent to client within 15 (fifteen) days from the date of receipt of final inputs from the customer in (PFC) section by In-charge (PFC).	
	Records to be maintained	Responsibility
i.	Assignment file (Hard/ soft copy)	DO
ii.	Records for detailed activity plan in the format no. CET-GEN-11.	TFL/ In-charge (LS)
iii.	Record of response time	In-charge (PFC)

ISSUED, CONTROLLED & APPROVED BY

(EXECUTIVE DIRECTOR)

Annex

(Reference procedure no. P 8.2-07)

ALLOTMENT OF ASSIGNMENT NUMBER

The assignment number will be given by In-charge (PFC) on 'Acceptance of assignment' as follows:

Customer codes/ DE (Detailed Engineering)/ Serial no. of assignment

CUSTOMER CODES

01	Bhilai Steel Plant (BSP)	15	Rashtriya Ispat Nigam Ltd. (RINL)
02	Bokaro Steel Limited (BSL)	16	Centre for Engineering & Technology (CET)
03	IISCO Steel Plant (ISP)	17	Other than SAIL
04	Durgapur Steel Plant (DSP)	18	Government of India
05	Rourkela Steel Plant (RSP)	19	(Reserved for future)
06	Alloy Steels Plant (ASP)	20	Corporate Office
07	Salem Steel Plant (SSP)	21	SAIL-SCL Kerala Ltd
08	Common to steel plant & general	22	SAIL Growth Works, Kulti (SGW)
09	Visvesvaraya Iron & Steel Plant (VISP)	23	Bokaro Power Supply Corporation Ltd. (BPSCL)
10	Research & Development Centre for Iron & Steel (RDCIS)	24	SAIL Refractory Unit (SRU)
11	Central Marketing Organisation (CMO)	25	Reserved
12	Chandrapur Ferro-alloy Plant (CFP)	26	Central Coal Supply Organisation (CCSO)
13	Management Training Institute (MTI)	27	SAIL & Tata Mining (S & T Mining)
14	Reserved	28	SAIL Refractory Co. Ltd. (SRCL)

Format no. CET-PFC-01

(Reference procedure no. P 8.2-07)

REQUISITION/ APPROVAL FOR "ACCEPTANCE OF ASSIGNMENT"

(To be filled in by Project Division after acceptance of assignment)

Assignment No. _____ Date _____

Title of assignment: _____

[Sl. Nos. 1 to 3 to be filled up by In-charge(PFC) and rest by In-charge (L/S)]

1. Source of assignment (Customer): _____
2. Ref. no. of letter from customer: _____
3. Title of assignment: _____
4. Whether discussed with customer: _____ Yes / No
5. Indicative cost of Project: _____
6. Scope and schedule of services to be rendered along with proposed hours:

	MP/AN/ FR /DIP/ DPR/ MNP	TS/ OS	DE	DS	PCA	Others (Pl specify)
Scope of services (tick applicable)						
Schedule (R-0) (Pl. Specify Date)						
Proposed Engg. hours						

Legend: MP-Master Plan, AN-Approach Note, FR-Feasibility Report, DIP-Draft Investment Proposal, DPR-Detailed Project Report, MNP-Mining Plan, TS-Tender Specification, OS-Ordering Specification, DE-Detailed Engineering, DS-Designers' Supervision, PCA-Post Commissioning Assistance.

7. (i) Lead section (Proposed): _____ (ii) HOD(LS) (Proposed): _____
8. Proposed TF (In consultation with concerned HODs)

Sl. No.	Name & Designation of Engineer	Section	Engg Hours *(upto R-0)
1.	(TFL)		
2.			
3.			
		TOTAL	

* Engg Hours are to be indicated for each section/ Sub-Centre/ unit office as a whole and not for individual engineer.

Additional hours required beyond R-0 will be obtained as per need by filling CET-PFC-02.

Date :

Name of HOD (LS):



(To be filled in by Project Division)

9. Budgeted Hours

Sl. No.	Section	Engg Hours (upto R-0)
1.		
2.		
3.		
	TOTAL	

10. Indicate, if any change is recommended in the scope of work/ services and schedule

[In Consultation with HOD (LS)]

11. Details of approval

Proposed by:

Name:

Designation:

Recommended by:

Name:

Designation:

Approved by:

Name:

Designation:

Date:

Forwarded for necessary action

Name of Desk Officer

- Distribution: 1. TFL through HOD (LS) along with schedule of monitoring of assignment.
2. HOD (SC) (Indicate name of Sub-Centre/ unit office) _____
3. TF through HODs.

Note: For any change in hours allotted, schedule and TF, separate approval is to be taken in format no. CET-PFC-02

This is a computer generated document and does not need signature

- 1. Title:** Checking/ approval of contractor’s drawings and documents
- 2. Purpose:** To ensure that drawings and documents submitted by suppliers are properly checked
- 3. Scope:** All type of drawings (including drawing list & design calculations) and documents submitted by customer's contractors for checking and approval
- 4. Overall responsibility:** HOD (LS)
- 5. Details of sequential activities:**

Sl. No.	Description	Responsibility
A.	<p>Check & finalize the following in consultation with TF:</p> <ul style="list-style-type: none"> i) Category-wise list of drawings/ documents to be submitted by contractor ii) Schedule of submission iii) Title blocks of drawings iv) No. of copies to be submitted for scrutiny v) No. of approved copies for distribution vi) Methodology of receipt, and return of drawings vii) Any other relevant point. <p>Note: In case of single package, TFL will also act as PL</p>	Package Leader (PL)
B.	Perform Scrutiny of drawings and accord observations/approval/acceptance as per contract.	TFL/ PL/ TFM
C.	Upload the stamped scrutinized drawing in SAN and communicate to TFL/PL	TFM
D	Communicate the status of drawing scrutiny alongwith stamped/scanned drawing to all concerned	TFL/PL
E.	<p>Review schedule and progress of drawings/ documents in assignment review meetings.</p> <ul style="list-style-type: none"> i) For multi package assignments PLs will maintain status of drawings ii) TFL will co-ordinate with PLs for obtaining status of drawing approval and compile them for review meetings. 	HOD (LS)



	Records to be maintained	
i.	Commented/ approved as noted copy of drawings duly stamped as per Annex, till final approval is accorded.	TF
ii.	Approved copy of drawing (1 print) duly stamped as per Annex and soft copy to be uploaded in SAN.	TF
iii.	Reference category drawing (1 print) duly stamped as per Annex and soft copy to be uploaded in SAN.	TF
iv.	List of drawings and schedule of receipt & dispatch of drgs.	TFL/ PL

ISSUED & CONTROLLED BY**APPROVED****(MANAGEMENT
REPRESENTATIVE)****(EXECUTIVE DIRECTOR)**

(Reference procedure no. P 8.2-08)

FOR APPROVAL CATEGORY

	APPROVED	
1.	Drawing approved for its general conformity to contract drawings and specifications.	
2.	This approval does not absolve the contractor of his responsibility for adequacy and completeness of design, suitability of materials, fitment of parts/ sub-assemblies at site, satisfactory operation of plant/ equipment offered and performance guarantees and other obligations as per contract.	
Name		Signature & Date
Designation	Section	

54 mm

	APPROVED AS NOTED	
1.	Drawing approved for its general conformity to contract drawings and specifications subject to incorporation of observations as noted.	
2.	Revised drawing should be submitted incorporating the observations noted for approval.	
3.	This approval does not absolve the contractor of his responsibility for adequacy and completeness of design, suitability of materials, fitment of parts/ sub-assemblies at site, satisfactory operation of plant/ equipment offered and performance guarantees and other obligations as per contract.	
Name		Signature & Date
Designation	Section	

70 mm

	NOT APPROVED COMMENTS FURNISHED	
1.	Drawing examined for its general conformity to contract drawings and specifications. The observations/ comments have been noted on the drawing/ are enclosed.	
2.	Revised drawing may be submitted for approval after incorporating the observations/ comments.	
Name		Signature & Date
Designation	Section	

54 mm

92 mm

FOR REFERENCE CATEGORY

	KEPT FOR REFERENCE		48 mm
1.	The drawing(s)/ document(s) submitted are intended for future reference.		
2.	The responsibility for adequacy and completeness of design, suitability of material, fitment of parts/ sub-parts lies solely with the Contractor and shall be in line with the contract.		
Name			
Designation	Section		

	KEPT FOR REFERENCE WITH NOTING		48 mm
1.	Revised drawing shall be submitted incorporating the observations.		
2.	The responsibility for adequacy and completeness of design, suitability of material, fitment of parts/ sub-parts lies solely with the Contractor and shall be in line with the contract.		
Name			
Designation	Section		

	COMMENTS FURNISHED		34 mm
1.	Revised drawing shall be submitted incorporating the comments furnished.		
Name			
Designation	Section		Signature & Date

92 mm



1. **Title:** Design
2. **Purpose:** To ensure that design calculations and design selections are as per project requirement
3. **Scope:** All designs prepared by CET including design changes viz. design/ capacity calculation, selection of technological processes, equipment and parameters
4. **Overall responsibility:** HOD
5. **Details of sequential activities:**

Sl. No.	Description	Responsibility
A.	Identify the design to be done based on the following: i) Requirements of the project ii) Internal assignment, if any iii) Any other source	TFM concerned/ TF
B.	Collect and scrutinise the input data for adequacy and obtain missing information, if any. List out assumptions.	TFM concerned/ TF
C.	Perform design calculations with the help of codes/ document. Prepare design sheet in hard/ soft copy as per the format no. CET-GEN-06 given in Annex.	TFM concerned/ TF
	<p>Note:</p> <ul style="list-style-type: none"> i) Latest IS codes or IPSS standard shall be used. Its year of issue must be mentioned. ii) All corrections in design sheet shall be signed in case of hard copy and shall be marked/ transmitted by e-mail in case of soft copy. iii) Total number of design sheets should be mentioned in the corresponding design summary sheet. iv) Obsolete design sheets and design summary sheets should be marked as 'Superseded'. v) Check a similar proven design, if available, use it during design, if required, 	
D.	Check the design calculations and the design sheets.	TFM concerned/ TF
E.	Prepare design summary sheet in hard/ soft copy as per the format no. CET-GEN-07 given in Annex and submit it along with related design sheets to designated engineer.	TFM concerned/ TF



F.	Verify design calculation with respect to the following: i) Input data ii) Assumptions made iii) Calculation part iv) Output data v) Relevant IS and IPSS standards vi) Statutory requirements	Designated engineer shall be authorized (Any engineer of the section other than TFM concerned)
G.	If not found correct: i) Discuss and give the sheets back to TFM concerned for necessary corrections. ii) Make necessary corrections and resubmit to designated engineer. iii) Follow step (F) onwards	Designated engineer
		TFM concerned/ TF
		Designated engineer
H.	If found correct, return the design summary sheet as verified, to the TFM concerned.	Designated Engineer.
I.	If information necessitating design changes is received from any sources given below, then inform TFL & HOD (concerned section). i) Customer's comments ii) Change in scope of work iii) Consequential changes due to change in corresponding design iv) Discussion among TF v) Design review of reports/ verification of specification vi) Changes due to site conditions during implementation vii) Any other reason	HOD (LS)
J.	Discuss and inform the TFM concerned/ TF.	TFL/ HOD (concerned section)
K.	Study the original design/ drawing and reasons for change, to decide whether change(s) are required or not.	TFM concerned/ TF
L.	If change(s) are required, follow step (C) onwards.	TFM concerned/ TF
M.	Make consequential changes, if any, in corresponding designs prepared in the section.	HOD (concerned section)
N.	In case of design change(s), inform TFL/ HOD (LS) for incorporating consequential design change(s) in other interface areas as required.	HOD (concerned section)



O.	If change(s) are not required : i) Discuss with HOD/ designated engineer ii) Inform TFL/ HOD (LS)/ HOD (SC) for keeping the agency informed, which made the request for change.	TFM concerned/ TF HOD (concerned section)
6.	Monitoring activities	Responsibility
A.	i) Monitor the number of QMS audit findings for non-conformities in design activities. (There should be continual decrease in the number of findings). ii) Ensure verification of design sheets, design summary sheets, and design calculation. (100% verification must be ensured)	HOD
	Records to be maintained	
i.	Soft/ scanned copy of design sheets	TFM concerned
ii.	Soft/ scanned copy of design summary sheet	TFM concerned

ISSUED & CONTROLLED BY

APPROVED

**(MANAGEMENT
REPRESENTATIVE)**

(EXECUTIVE DIRECTOR)



Format no. CET-GEN-06
(Reference procedure no. P 8.3-09)

DESIGN SHEET

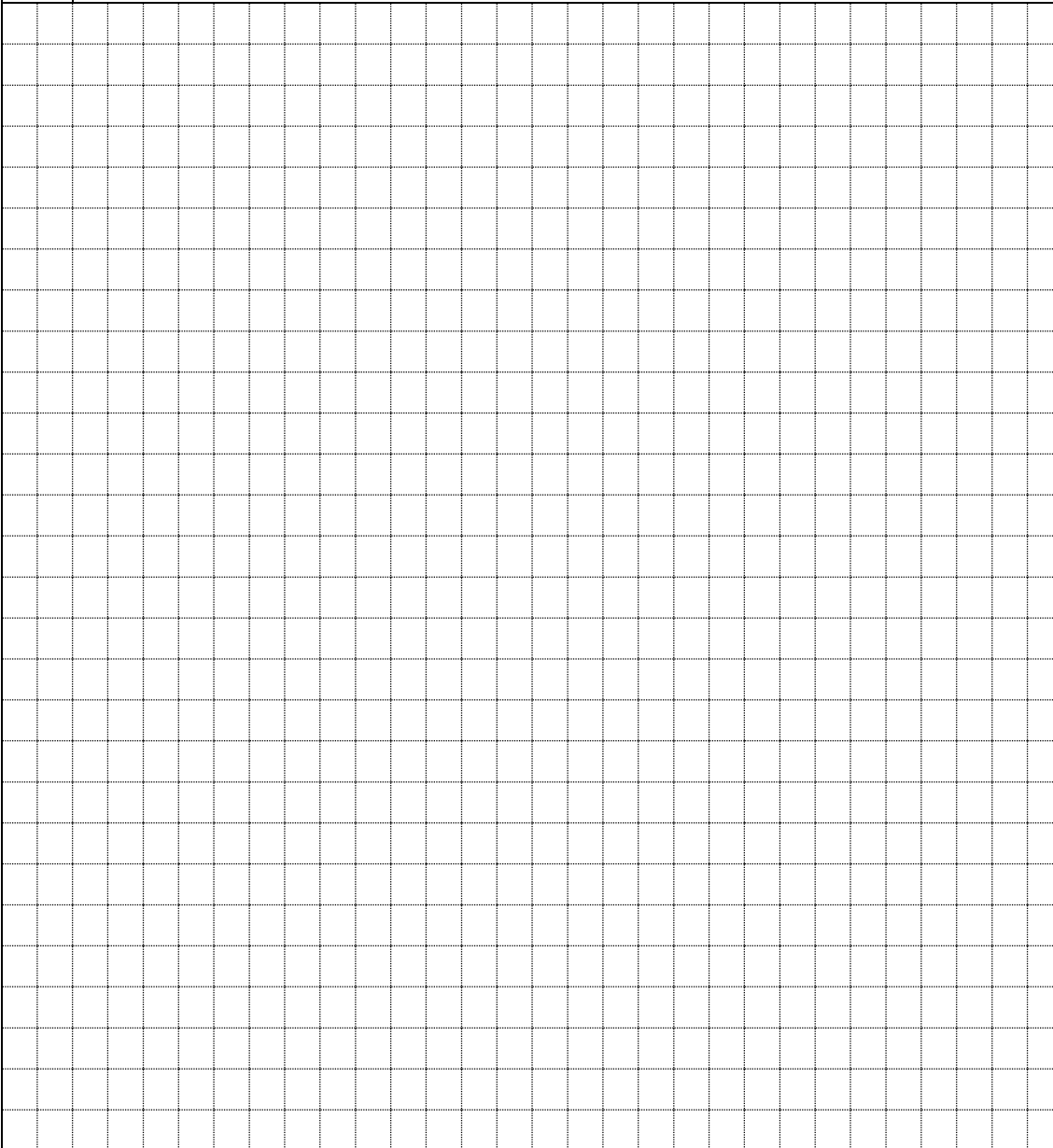
	SAIL/ CET	Assignment No. :	Page	of				
	Unit/ Component :							
								
					Designed by:			
					Date:			



Format no. CET-GEN-07

(Reference procedure no. P 8.3-09)

DESIGN SUMMARY SHEET

	SAIL/ CET	Assignment No.:
	Unit/ Component:	
Input Data/ Requirements:		
Standards used:		
Statutory Requirements: (applicable, if any)		
Assumptions made (if any):		
Implied requirements (if any):		
Output Data/ Design:		
No. of Design Sheets enclosed:		
Designed by:		Date:
Method of verification: Alternative calculations <input type="checkbox"/> Review of documents <input type="checkbox"/>		
(Tick appropriate box)		
Comparing with similar design <input type="checkbox"/>		Prototype <input type="checkbox"/>
Verified by:		Date:

1. **Title:** Design validation
2. **Purpose:** To carry out design validation of the envisaged performance guarantee parameters
3. **Scope:** All implemented projects for which TS has been issued by CET
4. **Overall responsibility:** HOD (LS)
5. **Details of sequential activities:**

Sl. No.	Description	Responsibility
A.	After preparation of post completion report, collect data for design validation as per performance guarantee parameters. Note: Design validation shall be done for each package/ TS	TF/ TFM concerned
B.	Analyse collected data with respect to performance guarantee parameters. Record in format no. CET-GEN-08 and submit to TFL/ HOD (LS) through HOD. Retain a copy.	TF/ TFM concerned
C.	If performance is not as per performance guarantee parameters, analyse the reasons with TF, work out corrective measures and learning point. Prepare consolidated report in format no. CET-GEN-08 and send it to In-charge (PFC).	HOD (LS)/ TFL
D.	If the performance is as per 'Design Validation Criteria', prepare a consolidated report in the format no. CET-GEN-08, and send to In-charge Projects.-PFC	HOD (LS)/ TFL
E.	Circulate design validation report to all HODs by e-mail.	In-charge (PFC)
Records to be maintained		
i.	Soft/ scanned copy of performance guarantee parameters	TFL
ii.	Soft/ scanned copy of consolidated design validation report	DO, TFL & HOD

ISSUED & CONTROLLED BY

APPROVED

**(MANAGEMENT
REPRESENTATIVE)**

(EXECUTIVE DIRECTOR)



Format no. CET-GEN-08
(Reference procedure no. P 8.3-10)

RECORD OF DESIGN VALIDATION

1. Assignment no: _____
2. Title of Assignment: _____
3. Title of TS: _____
4. Performance Guarantee Parameters as envisaged in the TS for the package:
(Attach separate sheet if required.)

5. Performance Data collected.
(Attach separate sheet if required)

6. Mention learning points for future designs, if any. :
(Attach separate sheet if required)

Signature/ Name of TF/ TFL

Designation:

- 1. Title:** Preparation & Approval of FR, AN, Scheme, Study Report & DPR
- 2. Purpose:** To ensure that reports are prepared and submitted timely.
- 3. Scope:** FR, AN, Scheme, Study Report & DPR
- 4. Overall responsibility:** In-charge (LS)
- 5. Details of sequential activities:**

Sl. No.	Description	Responsibility
A.	<p>After accepting the assignment, decide the following with TF:</p> <ul style="list-style-type: none"> i) Responsibilities of TFMs/TFL ii) Internal assignment to be issued iii) Time schedule for each activity to complete the report within committed time iv) Check availability of report in similar projects, if any, in Central database (Cdb). Take reference from Central database. v) Other relevant points 	In-charge (LS)
B.	<p>Get the write-up and all other relevant information from TFMs concerned as per detailed activity plan in the Format no. CET-GEN-11.</p> <p>Compile the information/ write-ups/ drawings, integrate the report and send to In-charge (LS)/ In-charge (SC). While preparing the write up, refer old similar reports, if any, of previous assignments uploaded in Central database and standard format uploaded in CET portal and Cost data base.</p> <p>Discuss the report among TFL, TFMs, In-charges concerned and finalize the draft report. Based on the draft report, send the requisite documents to CTE for preparation of cost estimate (Capital Cost/Block Cost).</p>	TFL/ In-charge (LS)/ In-charge(SC)
C.	<p>Prepare cost estimate, obtain approval of CGM(Projects) for project cost upto 30Cr or Organize Cost review Committee meeting for project cost>30Cr (as applicable as per relevant procedure), finalize cost estimate and send to In-charge (LS)/HOD(SC)/TFL</p>	CTE/ CGM(Projects)/ Cost Review Committee
D.	<ul style="list-style-type: none"> i) Incorporate the cost estimate write-ups in the final 	TFL/PL



	draft of documents.	
	<p>ii) Final document shall be routed in the following manner for vetting and approval:</p> <p>a. In-charge (LS) will send to CGM (LS) and CGM (LS) will send to In-charge (PFC).</p> <p>b. In-charge (SC) will send to In-charge (PFC) directly</p>	In-charge(LS)/ In-charge(SC)/ CGM(LS)
E.	<p>i) Organize presentation for design review.</p> <p>ii) Prepare list of observations during DR and communicate to TFL / PL for incorporation in the document.</p>	Desk Officer (DO)
F.	Present document for review and modify document, if required & submit to In-charge(LS).	TFL
G.	Send the finalized draft document (incorporating design review observations) to In-charge (PFC)	In-charge (LS)
H.	<p>Process for vetting and approval of document by CGM (Projects).</p> <p>After approval, send to customer (through Sub-Centre/ directly in case there is no Sub-Center) in pdf format and upload in central data base.</p>	In-charge (PFC)
I.	<p>i) Based on inputs of the Pre-NIT meeting, obtain final techno-commercial BQ from vendors and submit final FR/TS.</p> <p>ii) Repeat steps B to H for submission of revised FR.</p>	In-charge(L/S)/TFL
6.	Monitoring activities	Responsibility
A.	Ensure vetting and design review presentation of documents.	In-charge (PFC)
	Records to be maintained	
i.	Records of review and approval of documents	TFL/ In-charge (LS)
ii	Compliance to detailed activity plan in the format no. CET-GEN-11	TFL/ In-charge (LS)

ISSUED, CONTROLLED & APPROVED BY

(EXECUTIVE DIRECTOR)

Annex

(Reference procedure no. P 8.3-11)

NUMBERING OF DOCUMENTS (EXCEPT DRAWINGS)

Various documents issued by CET for different types of assignments shall be numbered as follows:

CET/ Customer Code/ Source Code/ Serial no. of assignment/ Type of document/
Discipline code/ Serial no. of document (in 2 digits)/ Revision no.

Example : CET/05/RN/1319/TS/EE/11/R=0

CET/05/RN/1178/FR/ST/01/R=0

Customer code, code for type of document, discipline code and source code are as follows:

CUSTOMER CODES

01	Bhilai Steel Plant (BSP)	15	Rashtriya Ispat Nigam Ltd. (RINL)
02	Bokaro Steel Limited (BSL)	16	Centre for Engineering & Technology (CET)
03	IISCO Steel Plant (ISP)	17	Other than SAIL
04	Durgapur Steel Plant (DSP)	18	Government of India
05	Rourkela Steel Plant (RSP)	19	(Reserved for future)
06	Alloy Steels Plant (ASP)	20	Corporate Office
07	Salem Steel Plant (SSP)	21	SAIL-SCL Kerala Ltd
08	Common to steel plant & general	22	SAIL Growth Works, Kulti (SGW)
09	Visvesvaraya Iron & Steel Plant (VISP)	23	Bokaro Power Supply Corporation Ltd. (BPSCL)
10	Research & Development Centre for Iron & Steel (RDCIS)	24	SAIL Refractory Unit (SRU)
11	Central Marketing Organisation (CMO)	25	Reserved
12	Chandrapur Ferro-alloy Plant (CFP)	26	Central Coal Supply Organisation (CCSO)
13	Management Training Institute (MTI)	27	SAIL & Tata Mining (S & T Mining)
14	Reserved	28	SAIL Refractory Co. Ltd. (SRCL)

CODE FOR TYPE OF DOCUMENT

Code should be given as per standard abbreviation specified in CET Procedures Manual.

DISCIPLINE CODES

ME	Mechanical	PR	Projects
EE	Electrical	CC	Coal, Coke & Chemicals
CE	Civil	RM	Raw Materials
SE	Structural	IR	Iron & Sinter
UT	Utilities	ST	Steel
RF	Rolling Mills	IT	Computer & Information Technology
RE	Refractory	CA	Process Control & Automation

Discipline codes are meant only for numbering the documents and drawings and should not be used as standard abbreviation.

SOURCE CODES

RN	Ranchi
BH	Bhilai Sub-Centre
BK	Bokaro Sub-Centre
BU	Burnpur Sub-Centre
DP	Durgapur Sub-Centre
RK	Rourkela Sub-Centre

- Documents generated in CET, not pertaining to any assignment number, should also be numbered but the number to be given may be decided on case-to-case basis.
- Reference to any document in the report/ specification should be in bold letters.
- Obsolete documents/ drawings (retained in CET) shall be marked as 'SUPERSEDED'.

Format no. CET-GEN-11
(Reference procedure no. P 8.3-11)

ACTIVITY PLANNING SCHEDULE

Assignment no.	
Title of Assignment	
Scope of work	

Time schedule of activities:

Sl. No.	Activity	Responsibility	Target Date	Actual Date	Remarks
i.					
ii.					
iii.					
iv.					
v.					
vi.					
vii.					
viii.					
ix.					
x.					
xi.					
xii.					

Name of TFL/ PL/ HOD(LS)

Designation:

Note:

1. Name of TFL/ HOD (LS), in case of FR and names of PL & TFL, in case of TS
2. Record should be maintained by TFL/ PL/ HOD (LS)

- 1. Title:** Preparation & approval of TS (For single package), Technical Note, Tender Document, Expression of Interest
- 2. Purpose:** To ensure that specifications are prepared and submitted timely
- 3. Scope:** All TSs of single package
- 4. Overall responsibility:** In-charge (LS)
- 5. Details of sequential activities:**

Sl. No.	Description	Responsibility
A.	For preparation of documents decide the following with TF: i) Responsibilities of each member of TF ii) Prepare record for above and communicate to TF and all concerned in soft form. iii) Check availability of specifications in similar projects, if any, in Central database. Take reference from Central database.	TFL
B.	Prepare action plan for preparation of document	TFL
C.	Issue internal assignment to TFMs concerned.	TFL
D.	Prepare write-up and drawings for respective portions of document and send to TFL. While preparing the write-ups, refer old similar specifications, if any, of previous assignments uploaded in Central database and standard format uploaded in CET portal.	TF
E.	Compile document. Process the same in soft form for verification by using format no. CET-GEN-09.	TFL
F.	Send the document to In-charge (LS)/ In-charge (SC) for review.	TFL
G.	Review the document with TFL, TFMs and concerned In-charges & finalize with review records.	TFL & In-charge (LS)/ In-charge (SC)
H.	Incorporate necessary changes, if any.	TFL & In-charge (LS)/ In-charge (SC)
I.	<ul style="list-style-type: none"> • <i>In case TS is in addition to FR/AN/SR etc., then skip this step (5.I) and follow from next Step 5.J.</i> • In case TS is the only deliverable in the scope : 	



	i) Get capital cost estimate sheet prepared, as applicable. ii) Send the document to In-charge (PFC) through concerned In-charge for review.	TFL
	iii) Organize presentation for TS review. Prepare list of observations during TS Review and communicate to TFL/ PL for incorporation in the document.	DO/ In-charge (PFC)
	Incorporate comments of TS review, if any.	TFL/ In-charge (LS)/ In-charge (SC)
J.	Put up to CGM (LS) through In-charge (LS) for approval	TFL
K.	After approval, send to In-charge Projects- PFC for issue	CGM (LS)
L.	Issue to customer through Sub-Centre/ directly in case there is no Sub-Center, by e-mail in pdf format. In case, lead section is Sub-Centre, document will be issued to customer directly with a copy to In-charge Projects-PFC.	In-charge (PFC)/ In-charge (SC)
M.	i. Based on inputs of the pre-NIT meeting, obtain final techno-commercial BQ from vendors and submit final TS and Cost estimate sheet (If TS is the only deliverable). ii. Repeat steps B to L for submission of revised document(s).	TFL/ In-charge (LS)/ In-charge (SC)
6.	Monitoring activities	Responsibility
A.	Ensure that document has been verified using format CET-GEN-09 (for each revision of document).	TFL
B.	Send interim reply to customer's queries within five days from the date of receipt of letter.	In-charge/ In-charge (LS)
	Records to be maintained	
i.	Records of verification of TS in format no. CET-GEN-09.	TF/ TFL
ii.	Records of compliance to activity plan.	TFL
iii.	Records of review and approval of document	DO
iv.	Record of review of TS by TFL, TFMs and In-charges concerned.	TFL

ISSUED, CONTROLLED & APPROVED BY

(EXECUTIVE DIRECTOR)

1. **Title:** Preparation & approval of TS (For multiple packages)
2. **Purpose:** To ensure that specifications are prepared and submitted timely
3. **Scope:** All TSs of multiple packages
4. **Overall responsibility:** In-charge (LS)
5. **Details of sequential activities:**

Sl. No.	Description	Responsibility
A.	For preparation of TSs decide the following with TF: i) Review the list of various packages with names of Package Leaders having main responsibility for the package. ii) Responsibilities of TFMs iii) Prepare record for above and communicate to TF and all concerned in soft form iv) Check availability of specifications in similar projects, if any, in central database. Take reference from central database.	TFL
B.	Prepare action plan for preparation of TS	TFL
C.	Issue internal assignment to TFMs concerned	PL
D.	Prepare write up and drawings for respective portions of TS and send to PL. While preparing the write up, refer old similar specifications, if any, of previous assignments uploaded in Central database and standard format uploaded in CET portal.	TF
E.	Compile TS. Process TS in soft form for verification by using format no.CET-GEN-09.	PL
F.	Send TS to TFL for vetting.	PL
G.	Review TS and send back to PL with comments, if any.	TFL
H.	Incorporate comments, if any and send TS to In-charge (PL) for vetting.	PL
I.	Review TS with TFMs, In-charge (LS), In-charges concerned, finalize and keep record of review.	In-charge (PL)/ PL



J.	<ul style="list-style-type: none"> • <i>In case TS is in addition to FR/AN/SR etc. then skip this step 5J and follow from Step 5.K.</i> • <i>In case TS is the only deliverable in the scope:</i> <ol style="list-style-type: none"> i) Get capital cost estimate sheet prepared, as applicable. ii) Send the document to In-charge (PFC) through concerned In-charge for review. 	PL/TFL
	<ol style="list-style-type: none"> i) Organize presentation for TS review. ii) Prepare list of observations during TS Review and communicate to TFL/ PL for incorporation in the document. 	DO/ In-charge (PFC)
	Incorporate comments of TS review, if any.	PL/ In-charge (PL)/ In-charge (SC)
K.	Send TS after incorporating comments of TS review to CGM (PL) through In-charge (PL) for approval.	PL
L.	Send approved TS to In-charge Projects-PFC.	CGM (PL)
M.	Issue to customer through Sub-Centre/ directly in case there is no sub-center, by e-mail in pdf format. In case lead section is Sub-Centre, TS will be issued to customer directly with a copy to In-charge Projects-PFC.	In-charge Projects-PFC/ In-charge (SC)
N.	<ol style="list-style-type: none"> i. Based on inputs of the pre-NIT meeting, obtain final techno-commercial BQ from vendors and submit final TS and Cost estimate sheet (If TS is the only deliverable). ii. Repeat steps B to M for submission of revised document(s). 	TFL/ In-charge (LS)/ In-charge (SC)
6.	Monitoring activities	Responsibility
A.	Ensure that TS has been verified using format no. CET-GEN-09 (for each revision of TS).	TFL
	Records to be maintained	
i.	Records of verification of TS in format no. CET-GEN-09.	TF/ TFL
ii	Records of compliance to activity plan	TFL
iii.	Records of TS review and approval of TS	DO
iv	Record of review of TS by TFL/PL, TFMs, In-charge (LS)/ In-charge (PL) and In-charges concerned.	PL



ISSUED, CONTROLLED & APPROVED BY

(EXECUTIVE DIRECTOR)



CET-GEN-09

(Reference procedure no. P 8.3-12)

VERIFICATION OF TS

Document no./ Title of TS: CET/

Title of Assignment:

Name of TFL/ Name of Package leader:

Sl. No.	PARAMETER	CHECK		REMARKS
		OK	NOT OK	
1.	Completeness w.r.t structure, chapters, annexes, drawings, schedules, language etc.			
2.	Scope of work is covered			
3.	Input details			
4.	Output details			
5.	Technical specifications			
6.	IS codes mentioned with latest year of issue			
7.	Environmental requirements			
8.	Safety requirements			
9.	Packaging, handling & storage requirements			
10.	Inspection & testing requirements			
11.	Performance guarantee parameters			
12.	Implementation period			
13.	Other check point, if any			

Note: In case of multi-package assignments, Point nos. 5, 10 and 11 may be checked by In-charge of Package Leader and signed in remarks column before sending to TFL for verification.

Name of Package Leader: Designation: Date:	Name of TFL / In-charge (LS): Designation: Date:
--	--

1. **Title:** Preparation & approval of OS
2. **Purpose:** To ensure that OSs are prepared and submitted as per schedule.
3. **Scope:** All OSs
4. **Overall responsibility:** HOD (LS)
5. **Details of sequential activities:**

Sl. No.	Description	Responsibility
A.	After accepting the assignment, Issue internal assignment, (in format no. CET-GEN-04.) if required, to concerned HOD for preparation of OS.	HOD (LS)
B.	Assign the job to TFMs concerned and discuss details.	HOD
C.	Review the following (with TF, if required): i) Scope of work ii) Input data/ document requirements iii) Internal assignments issued in format no. CET-GEN-04. iv) Time schedule for various activities	PL
D.	Prepare detailed activity plan in the format no-CET-GEN-11 enclosed with P 8.3-11 based on the above and keep in file.	PL/ TFL
E.	Prepare OS. Get OS checked by one engineer of section designated by HOD for completeness & correctness. Process OS for verification. Use format no: CET-GEN-05 given in Annex for verification. Note: HOD will designate an engineer for verification, other than the PL concerned	TFL
F.	Verify the OS using format no. CET-GEN-05 given in Annex.	Designated engineer
G.	Send OS to TFL for vetting.	PL
H.	Review OS and send back to PL with comments, if any.	TFL



I.	Send OS to HOD (PL) for vetting.	PL
J.	Review OS with TFMs, HOD (LS), HOD (PL) and HODs concerned. Finalize and keep record of review.	PL/ HOD (PL)
K.	Send the OS after making necessary corrections to CGM (PL) through HOD (PL) for approval.	PL
L.	Send approved OS to In-charge (PFC).	CGM (PL)
M.	Issue to customer through Sub-Centre/ directly in case there is no sub-center, by e-mail in pdf format. In case lead section is Sub-Centre, OS will be issued to customer directly with a copy to In-charge (PFC).	In-charge (PFC)/ HOD (SC)
6.	Monitoring activities	Responsibility
A.	Ensure that OS has been verified using proper format no. CET-GEN-05 (for each revision of OS).	TFL
B.	Send interim reply to customer's queries within five days from the date of receipt of letter.	HOD / HOD (LS)
	Records to be maintained	
i.	Record of verification of OS	PL
ii	Records for detailed activity plan in the format no. CET-GEN-11.	PL/ TFL

ISSUED & CONTROLLED BY

APPROVED

**(MANAGEMENT
REPRESENTATIVE)**

(EXECUTIVE DIRECTOR)

Format no. CET-GEN-05

(Reference procedure no. P 8.3-13)

VERIFICATION OF ORDERING SPECIFICATION

Ordering Specification no. : CET/

Title of Assignment:

Name of PL / TF:

Sl. No.	PARAMETER	CHECK		REMARKS
		OK	NOT OK	
1.	Completeness w.r.t structure, chapters, annexes, drawings, schedules, language etc.			
2.	Scope of work is covered			
3.	Input details			
4.	Output details			
5.	Technical specification			
6.	Applicable codes with year of issue			
7.	Safety requirements			
8.	Environmental requirements			
9.	Packaging, handling & storage requirements			
10.	Inspection & testing requirements			
11.	Time schedule			
12.	Other check point, if any			

(Signature/ Name of HOD of section concerned)

Designation:

Date:

- 1. Title:** Preparation & approval of MNP
- 2. Purpose:** To ensure that MNP is prepared and submitted timely
- 3. Scope:** MNP
- 4. Overall responsibility:** HOD (LS)
- 5. Details of sequential activities:**

Sl. No.	Description	Responsibility
A.	After accepting the assignment, the assignment discuss and decide the following with TF: i) Drawings and documents required ii) Responsibilities of each member of TF iii) Time schedule for each activity to complete the job within committed time iv) Internal assignment, if any, to be issued	HOD(LS)
B.	Prepare detailed activity plan in the format no. CET-GEN-11 enclosed with P 8.3-11 as per decisions of Sl. no. A and give to all concerned.	TFL
C.	Prepare document as per plan prepared in Sl. No. B and in conformity to the guidelines/ format, issued by IBM.	TF
D.	Verify MNP using format no. CET-GEN-10.	A Mining Engineer/ Geologist who is a member of TF
E.	Send the MNP to In-charge (PFC) by e-mail for checking through HOD (LS).	TFL
F.	Check documents and send to HOD (LS) in soft form.	In-charge (PFC)
G.	Issue MNP to customer/ IBM	HOD (LS)
H.	Examine customer's/ IBM's comments/ observations, if any, and incorporate modifications required in the MNP.	TF
I.	Follow steps 'D' onwards till the MNP is approved by IBM.	TFL
J.	Send the approved MNP to In-charge (PFC) through HOD (LS).	TFL



6.	Monitoring activities	Responsibility
A.	Ensure that MNP has been verified using format no. CET-GEN-10 (for each revision of MNP).	TFL
B.	Send interim reply to customer's queries within five days from the date of receipt of letter.	HOD/ HOD (LS)
Records to be maintained		
i.	Records of verification of MNP.	TFL/ HOD (LS)
ii	Records for detailed activity plan in format no. CET-GEN-11.	TFL/ HOD(LS)

ISSUED & CONTROLLED BY

APPROVED

**(MANAGEMENT
REPRESENTATIVE)**

(EXECUTIVE DIRECTOR)

Format no. CET-GEN-10

(Reference procedure no. P 8.3-14)

VERIFICATION OF MINING PLAN

MNP no: CET/

Title of Assignment:

Name of designated QP:

Sl. No.	PARAMETER	CHECK		REMARKS
		OK	NOT OK	
1.	Format, content and numbering as per IBM guidelines			
2.	Completeness w.r.t chapters, annexes, drawings, language, format, content, numbering etc.			
3.	Interfaces - cross reference and linkages of information, annexes, data and drawings			
4.	Scope of work is covered			
5.	Chapterisation as per IBM guidelines			
6.	Consent letter/ Undertaking/ Certificate from customer			
7.	Various certificates as per requirements by QP			
8.	Certificate of correctness & updating of plan on each & every drawings			
9.	Signature of QP on each and every drawing and on text document			
10.	Other check point, if any			

(Signature/ Name of designated QP)

Designation:

Date:

(Signature/Name of TFL)

Designation:

Date:



- 1. Title:** Preparation & approval of Draft Investment Proposal (DIP)
- 2. Purpose:** To ensure that DIP are prepared and submitted timely
- 3. Scope:** All DIPs prepared by CET
- 4. Overall responsibility:** In-charge (LS)
- 5. Details of sequential activities:**

Sl. No.	Description	Responsibility
A.	Send the request received from plant for DIP to In-charge (LS) with copy to In-charge Projects-PFC and In-charge (CTE)	In-charge (SC)
B.	Study the assignment and discuss with TFL and TFM(Project-CTE)	In-charge (LS)
C.	<ul style="list-style-type: none"> • Prepare technical write up for DIP in the standard format based on the related documents, discussion with the customer along with implementation schedule. • Send to TFM(CTE) for incorporation of cost & financial analysis write-up through In-charge(LS). 	TFL
D.	Prepare/ update the cost estimates, financial analysis, variance Analysis including graphs/ annexures in the standard format and incorporate in the draft write-up of DIP. Check and send to In-charge (LS)/ TFL through In-charge (CTE).	TFM (CTE)
E.	Vet the compiled DIP, check with the "Checklist for DIP" and finalize the DIP. Send to In-charge (LS).	TFL
F.	Verify DIP and send it to CGM(LS) for vetting.	In-charge (LS)
G.	After vetting and finalization, send DIP for approval by CGM(Projects).	CGM(LS)
H.	<ul style="list-style-type: none"> • Approve the DIP after discussion with ED(CET). • Send the approved DIP to In-charge (Proj-PFC) for issue to client. 	CGM (Projects)
I.	Issue the approved DIP to the customer through In-charge (SC) or directly to customer, if there is no Sub-	In-charge(PFC)



	Centre with copies to In-charge (LS), TFL, In-charge (CTE) and ED's Secretariat.	
	Records to be maintained	
i.	Copy of DIP	TFL, In-charge (PFC), In-charge (CTE)

ISSUED, CONTROLLED & APPROVED BY

(EXECUTIVE DIRECTOR)

- 1) **Title** : Evaluation of bid (Technical part)
- 2) **Purpose** : To ensure that technical specifications of the bids meet project requirements as per NIT
- 3) **Scope** : Bids (Technical part) evaluated by CET
- 4) **Overall responsibility** : In-charge (PL)
- 5) **Details of sequential activities:**

Sl. No.	Description	Responsibility
5-1)	On receipt of bids, ensure completeness and send documents to In-charge Lead section (LS)/ In-charge Package leader (PL), as applicable, with intimation to In-charge (PFC)	Sub-centres/ CET, Ranchi
5-2)	i) Prepare comparative statements with respect to TS & EC as mentioned in NIT Document. ii) Seek necessary clarifications from bidders, if required, with intimation to client (Correspondences with bidders to be made through PL) iii) Organize tender discussions, if required, invite Plant/ Unit for participation with due intimation to ED (Projects), ISPs	PL & TFMs
5-3)	Confirm compliance of bids wrt TS & EC as mentioned in NIT documents. Outstanding issues, (if any), to be informed to PL for inclusion in Technical Evaluation Report (TER)	TFMs
5-4)	Prepare draft TER as per standard format and submit to In-charge (PL) for review	PL
5-5)	Evaluate draft TER, ensure incorporation of changes (if any) and submit updated draft TER to CGM (PL)	In-charge (PL)
5-6)	Review & finalize TER with In-charge (PL) & PL. Send finalized TER to In-charge (PFC) with intimation to In-charge (PL)	CGM (PL)
5-7)	Vet finalized TER. Ensure incorporation of changes (if any) by PL and submit updated final TER to CGM (Projects) with intimation to CGM (PL)	In-charge (PFC)
5-8)	Review/ approve final TER and send to In-charge (PFC) with intimation to CGM (PL)	CGM (Projects)
5-9)	Submit approved TER (pdf copy) to customer (with due confidentiality) through In-charge (Sub-centre at ISPs)/ directly to other Units. Intimate all concerned	In-charge (PFC)

Steps to be followed for revision of TER

5-10)	Follow above steps 5-4) to 5-7) as applicable	PL, In-charge (PL), CGM (PL), In- charge (PFC)
5-11)	Vet & submit TER (R1) to CGM (Projects)	In-charge (PFC)
5-12)	i. In case of change in recommendations of TER (R1) wrt TER (R0), review/ ensure incorporation of changes (if any) and submit final TER (R1) to ED (CET) for approval	CGM (Projects)
	ii. Review/ approve TER (R1) & send to CGM (Projects)	ED (CET)
	iii. In case of no change in recommendations of TER (R1) wrt TER (R0), review/ ensure incorporation of changes (if any) and approve final TER (R1) with prior intimation to ED (CET) of changes in TER (R0)	CGM (Projects)
	iv. Send approved TER (R1) to In-charge (PFC) with intimation to CGM (PL)	
5-13)	Submit approved TER (R1) (pdf copy) to customer (with due confidentiality) through In-charge (Sub-centre at ISPs)/ directly to other Units. Intimate all concerned	In-charge (PFC)

ISSUED, CONTROLLED & APPROVED BY**(EXECUTIVE DIRECTOR)**



1. **Title:** Price bid evaluation
2. **Purpose:** To ensure proper evaluation of price bids
3. **Scope:** Price bids for which specific request for evaluation has been received from customer and agreed by CET
4. **Overall responsibility:** In-charge CTE
5. **Details of sequential activities:**

Sl. No.	Description	Responsibility
A.	Send the request for price bid evaluation (PBE) to In-charge Projects –CTE with a copy to In-charge (PFC)and In-charge (LS)	In-charge (SC)
C.	Seek necessary clarifications/ details etc., if required, from the customer through HOD (SC).	TFM (CTE)
D.	Prepare PBE based on package cost, and evaluate price bids	TFM (CTE) I/c CTE
E.	Submit the PBE to In-charge Projects- CTE. Note: All pages and annexes of PBE should have identification (assignment no.), page no.	TFM (CTE)
F.	Verify PBE and obtain approval of CGM (Projects) and send the approved PBE to In-charge (PFC)with a copy to TFM CTE	In-charge CTE
H.	Issue the approved PBE to the customer through HOD (SC) or directly to customer, if there is no Sub-Centre with copies to In-charge(LS), HOD(Projects–CTE) and ED’s Secretariat.	In-charge ((PFC))

ISSUED & CONTROLLED BY

APPROVED

**(MANAGEMENT
REPRESENTATIVE)**

(EXECUTIVE DIRECTOR)

1. **Title:** Preparation of drawings
2. **Purpose:** To ensure that prepared drawings are correct
3. **Scope:** All drawings prepared by CET
4. **Overall responsibility:** HOD
5. **Details of sequential activities:**

Sl. No.	Description	Responsibility
A.	Identify drawings to be prepared based on the following: <ol style="list-style-type: none"> i) Internal assignment ii) Scope of work iii) Discussion among TF iv) Design calculation v) Any other source Note: For DE drawings, an updated list of drawings with submission schedule should be prepared by concerned engineer/ TF and sent through HOD to TFL. TFL shall compile the schedule and send to DO through In-charge (PFC)for monitoring.	TFL/ TFM
B.	Study and explain the details required for preparing the drawing.	TFL/ TFM
C.	Record the details of drawing as per the format given in Annex.	TFL/ TFM
D.	Go through details and conceptualise by taking help from concerned engineer, if necessary.	TFL/ TFM
E.	Prepare drawings as per details provided using standard title block as given in Annex.	TFL/ TFM
F.	During preparation of drawings, check it periodically for the progress of the drawing.	TFL/ TFM
G.	Take a check print or forward soft copy after completion of the drawing and submit to concerned engineer	TFL/ TFM
H.	Check the print/ soft copy.	TFL/ TFM
I.	If not found correct:	
	i) Make necessary corrections on check print/ soft copy	TFL/ TFM
	ii) Get corrections incorporated as per (i)	TFL/ TFM
	iii) Check the drawing finally	TFL/ TFM



J.	If found correct :	
	i) Write drawing number as per system for numbering of drawings given in Annex including revision status.	TFL/ TFM
	ii) Write the purpose of drawing e.g. 'Preliminary', 'For Tender Purpose Only' etc.	
	iii) Put signature or write name in the 'DRAWN' column and hand over to TFM concerned.	
K.	Sign/ Name in the 'DESIGNED' column.	TFL/ TFM
L.	Process for checking and approval of drawings as per procedure no. P 8.3-19.	TFL/ TFM
	Records to be maintained	
i.	Records of status of drawings prepared in format no. CET-GEN-03.	HOD
ii.	Updated list of drawings with submission schedule.	TFL/ TFM

ISSUED & CONTROLLED BY

APPROVED

**(MANAGEMENT
REPRESENTATIVE)**

(EXECUTIVE DIRECTOR)

Annex

(Reference procedure no. P8.3-18)

TITLE BLOCK FORMAT AND NUMBERING OF DRAWINGS

1. CET's title block shall be as follows:

								CLEARANCE			 Steel Authority of India Limited स्टील अथॉरिटी ऑफ इंडिया लिमिटेड Centre for Engineering & Technology सेंटर फॉर इंजीनियरिंग एण्ड टेक्नोलॉजी			
								Sec	By	Dt				
											PLANT () :			
											DRAWN	UNIT () :		
											DESIGNED			
											CHECKED			
											APPROVED	SCALE	DRG NO.	REV R=
											DATE	SIZE A-	SHEET OF	
Nos	Dt	Remarks	By	Appd	Drg no.	Details								
REVISIONS			REF DRAWINGS			Notes								

2. Detailed engineering drawings released for various purposes will be stamped for its purpose (like 'For Approval', 'For Reference', 'For Construction' etc.) and signed with date by concerned engineer on each print before release.

3. Wherever CET works on an assignment in association with other organisation as main consultant, the hierarchy of putting title block and emblem of various agencies should be as follows:

a) All drawings (design and detailing) prepared by CET (including those prepared by vendors for drafting work) will carry title block of CET at the bottom. Emblem and drawing number of all the agencies like main consultant, customer etc., if any, will appear suitably one over another above CET's title block.

Example:

											Customer's title block if required				
											Other agency's title block, if required (Main consultant)				
								CLEARANCE			 Authority of India Limited अथॉरिटी ऑफ इंडिया लिमिटेड for Engineering & Technology सेंटर फॉर इंजीनियरिंग एण्ड टेक्नोलॉजी				
								Sec	By	Dt					
												PLANT () :			
												DRAWN	UNIT () :		
												DESIGNED			
												CHECKED			
												APPROVED	SCALE	DRG NO.	REV R=
												DATE	SIZE A-	SHEET OF	
Nos	Dt	Remarks	By	Appd	Drg no.	Details									
REVISIONS			REF DRAWINGS			Notes									

b) If the job of design and detailing is off-loaded by CET to any sub-vendor, title block of the corresponding sub-vendor will appear at the bottom. Emblem, name and drawing no. of CET will appear above it. Other

agency's (like main consultant or customer) emblem, name and drawing no. may appear above it, if required.

Example:

	Customer's title block if required
	Main consultant's block if required
	Steel Authority of India Limited स्टील अथॉरिटी ऑफ इंडिया लिमिटेड Centre for Engineering & Technology सेंटर फॉर इंजीनियरिंग एण्ड टेक्नोलॉजी
Drawing no.	CET
	Sub vendor's title block

- c) In case the design and detailed drawing is prepared by any sub-vendor of CET and for any reason the sub-vendor's title block can not appear on the drawing, CET's title block shall be used at the bottom. Sub-vendor's reference drawing number shall be given in a frame above the CET title block. Other agency's (like main consultant or customer) emblem, name and drawing no. may appear above it, as required.

Example:

	Other agency's title block, if required (Customer)		
	Other agency's title block (Main consultant)		
	Sub-vendor's drg. no. (no emblem)		
	Steel Authority of India Limited स्टील अथॉरिटी ऑफ इंडिया लिमिटेड Centre for Engineering & Technology सेंटर फॉर इंजीनियरिंग एण्ड टेक्नोलॉजी		
	PLANT () :		
DRAWN	UNIT () :		
DESIGNED			
CHECKED			
APPROVED	SCALE	DRG.NO.	REV R=
DATE	SIZE A-	SHEET OF	

- d) In case a number of A4 sheets are prepared for a particular drawing (having same drawing number), the first sheet (sheet 1 of ...) will have the

title block only and other sheets need not have the title block but only the drawing number and sheet number.

4. Drawing numbering system of CET shall be as follows:

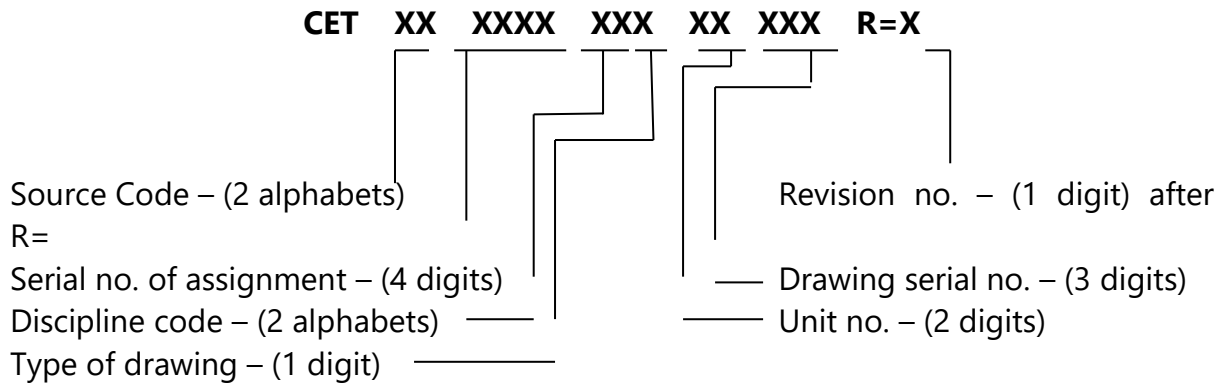

- a) While referring in text form, the drawing number is to be written with necessary gaps.
- b) Source code shall be as per Sl. no. 5 below and assignment no. shall be as in practice.
- c) Discipline codes shall be as given in Sl. no. 6 below.
- d) Codes for type of drawing shall be as given in Sl. no. 7 below and written after discipline code without a gap.
- e) Unit code shall be assignment specific and shall be decided by TF in case to case basis.
- f) For FR/ TS etc. (ie. For reports and specification before implementation stage), 2 digits of the unit number shall be 00. Specific unit number is to be given in implementation stage only.

Examples:

A. Numbering of a Technological Layout drawing prepared by Steel section for assignment no. 05/DE/1178.

CET RN 1178 ST2 00 001 R=0

Explanation: ST2 denotes Steel section and technological layout drawing. 00 denotes unit no. which is not allotted since the assignment is for FR preparation. 001 is the serial no. of drawing.

B. Numbering of a fabrication drawing prepared by Structural section for assignment no. 02/DE/1262.

CET RN 1262 SE2 05 002 R=0

Explanation: SE2 denotes Structural section & fabrication category drawing. Unit no. 05 may denote 'Vessel Repair Platform' (as decided by

TF and should be specific for this assignment) and 002 is the serial no. of drawing.

- If the drawing is for study and/ or data bank purpose only and is not a part of any assignment, the assignment number code should be shown as 0000. Other things shall remain same as that in the assignment drawings. Example – CET RN 0000 ME1 00 001 R=0.
- Reference to any drawing in the report shall be in bold letters.

5. Source Codes shall be as follows:

RN	Ranchi
BH	Bhilai Sub-Centre
BK	Bokaro Sub-Centre
RK	Rourkela Sub-Centre
DP	Durgapur Sub-Centre
BU	Burnpur Sub-Centre

6. Discipline Codes shall be as follows:

Discipline	Code	Discipline	Code
Mechanical	ME	Projects	PR
Electrical	EE	Coal, Coke & Chemical	CC
Civil	CE	Raw Materials	RM
Structural	SE	Iron & Sinter	IR
Utilities	UT	Steel	ST
Refractory	RE	Rolling Mills	RF
Computer & Information Technology	IT	Process Control & Automation	CA

Discipline codes are meant only for numbering the documents and drawings and should not be used as standard abbreviation.

7. Codes for type of drawings shall be as follows:

Section	Category	Disc. Code	Code	Section	Category	Disc. Code	Code
Technology Sections	General	As in Sl. 6 above	0	Civil	General	CE	0
	Schematic Drawing		1		Excavation Plan	CE	1
	Technological Layout/ General Layout		2		Shuttering details & Insert details Drawing	CE	2
	GA Drawing		3		Reinforcement details & Bar Bending Schedule	CE	3
	Slice Plans		4		Architectural Drawing	CE	4
	Excavation plans & sections		5				
	Geological plans & sections		6	Structural	General	SE	0
	Statutory plans		7		Design Drawing	SE	1
				Fabrication Drawing	SE	2	
Mechanical	General	ME	0				
	Equipment/ Shop Layout	ME	1				
	GA Drawing	ME	2				
	Sub Assembly Drawing	ME	3				
	Detailed Manufacturing Drawing	ME	4				
Utilities	General	UT	0	Electrical	General	EE	0
	Process Plant & Equipment Drawings	UT	1		Single Line Diagram	EE	1
	Fluid System Drawings	UT	2		Control Schematics	EE	2
Refractory	Production Unit Drawings	RE	0		General Arrangement Drawing	EE	3
	Brick Shape Drawings	RE	1		Equipment Layout	EE	4
	Refractory Erection Drawings	RE	2		Illumination Layout	EE	5
Process Control & Automation	General	CA	0		Earthing Layout	EE	6
	Automation system configuration diagram	CA	1	Cable Schedule, Terminal diagram/	EE	7	
	P & I Diagram	CA	2				
	GA drawing	CA	3				



	Schematic diagram	CA	4		chart		
Computer & Information Technology	General	IT	0		Automation configuration, I/O list/ Logic diagram	EE	8
	Schematic drawing	IT	1		List of manuals/ drawings/ equipment/ drive, control philosophy, design calculations & other misc.	EE	9

Format no. CET-GEN-03
(Reference procedure no. P 8.3-18)

RECORD OF DRAWINGS

Sl. No.	Description of drg.	Drawing no.	Size of Drawing

Name of TFM concerned	Date of issue			
	R=0	R=1	R=2	R=3

Note: This record shall be maintained by each section/ sub-centre/ unit office. The above list may be maintained in register or file or electronic media and may have additional information, if required.

1. **Title:** Checking and approval of drawings
2. **Purpose:** To check and approve all drawings so that error free drawings are issued to customers
3. **Scope:** All drawings prepared and issued by CET
4. **Overall responsibility:** HOD
5. **Details of sequential activities:**

Sl. No.	Description	Responsibility
A.	i) Engineer concerned to forward soft copy of engineering drawing prepared as per procedure no-P 8.3-18 Note: Designated engineer (who does checking) should be other than the engineer concerned who has designed and must be authorised to check.	Engineer concerned
B.	Check technical parameters/ details as per check points below i) Drawing title block ii) Size and scale of drawing iii) Reference drawing nos. iv) Bill of material v) Notes on drawing including revision status and purpose. vi) Technical parameters including assumptions, if any, used for designing the system vii) Design basis as appropriate for the particular drawing refer records viz. design sheets & design summary sheets as required for checking.	Designated engineer
C.	If technical parameters are not correct, return the commented drawing in soft copy to engineer concerned.	Designated engineer
D.	Receive corrected drawings from engineer concerned.	Designated engineer
E.	Check the drawings as per corrections made	Designated engineer
F.	If found correct, sign in hard copy/ write name in soft copy and forward to designated/ engineer concerned.	Designated engineer
G.	i) Identify appropriate sections from whom clearances have to be taken. ii) Take clearance on General Arrangement (GA) drawings from other sections as appropriate but necessarily from section who has assigned the job and clearances will be given by concerned engineer	Engineer concerned Engineer concerned



	of the section by putting name and date in soft copy and return back to engineer concerned.	
H.	Put up for approval to HOD/ designated engineer. Note: HOD/ designated engineer (who accords approval) must be authorized to approve.	Engineer concerned
I.	i) Check the drawing. ii) Check the records for following, if required: a) Input & output requirements b) Clearances from appropriate agencies.	HOD/ Designated engineer
J.	If not found correct discuss with engineer concerned for necessary corrections.	HOD/ Designated engineer
K.	If found correct, sign in hard copy/ write name with date in soft copy and forward drawing back to engineer concerned.	HOD/ Designated engineer
	Monitoring activities	Responsibility
A.	i) Ensure verification of drawings (100% verification must be ensured)	HOD
	Records to be maintained	
i.	Approved copy of drawing. Keep back up of data.	Engineer concerned

ISSUED & CONTROLLED BY

APPROVED

**(MANAGEMENT
REPRESENTATIVE)**

(EXECUTIVE DIRECTOR)

1. **Title:** Revision of drawings
2. **Purpose:** To ensure that changes are correctly incorporated in drawings
3. **Scope:** All drawings issued by CET
4. **Overall responsibility:** HOD concerned
5. **Details of sequential activities:**

Sl. No.	Description	Responsibility
A.	Identify drawings to be revised based on the following: i) Customer's comments ii) Change in scope of work iii) Consequential changes due to change in other drawings iv) Discussion among TF v) Design review of reports/ verification of specification vi) Design changes/ changes due to site conditions during implementation vii) Any other reason	Engineer concerned
B.	Revise the drawing, mark the revisions, fill up column for revision in the drawing, giving reason and details of revision and forward to concerned agencies. (Duly signed in case of hard copy).	Engineer concerned
	<p>Note:</p> i) Change should be done either by the same person who had designed the drawing earlier or by anyone who has access to earlier design considerations and is authorised to design. ii) If the drawing is under revision (hard/ soft form), the drawing should be marked as "under revision" in the drawing list till it is finally revised. iii) If drawing is prepared using electronic media, names of signatories of original drawing shall be written while revising the drawing. All changes should be marked on the drawing by symbols similar to conventional drawing. The details should be recorded in the revision column and signed by concerned engineer in 'BY' column.	
C.	Obtain clearances from the agencies with whom the clearances were taken in the previous revision and	Engineer concerned



	record either in the drawing, if space is available, otherwise keep in the assigned folder in soft form.	
D.	Record the details of drawing as per format CET-GEN-03 and store in soft form.	Engineer concerned
E.	Make consequential changes in corresponding drawings prepared by same section.	Engineer concerned
F.	Verify and sign/ name in the 'APPROVED' column. Note: Change should be verified/ approved either by the same person who had approved the drawing earlier or by anyone who has access to earlier design considerations and is authorized for approval. It should be recorded with signatures/ name in the "APPROVED" column for revision.	HOD/ HOD(LS)
G.	Intimate TFL/ HOD (LS) through HOD for consequential changes in other drawings of interface areas, as required.	Engineer concerned
	Records to be maintained	
i.	Final copy of drawing with changes made.	Engineer concerned
ii.	Records of status of drawings prepared in format no. CET-GEN-03.	HOD concerned

ISSUED & CONTROLLED BY

APPROVED

**(MANAGEMENT
REPRESENTATIVE)**

(EXECUTIVE DIRECTOR)

- 1. Title:** Recommending suppliers for issue of limited tender enquiry (LTE)
- 2. Purpose:** To ensure that selected suppliers are technically competent for executing the order, if awarded to them
- 3. Scope:** All assignments for which TSs are prepared by CET
- 4. Overall responsibility:** HOD (PL)
- 5. Details of sequential activities:**

Sl. No.	Description	Responsibility						
A.	List out the probable suppliers for the package for which TS is being prepared, based on the following (refer part-1 of format enclosed in Annex): i) Suppliers known in the field ii) Letters received from suppliers iii) Advertisement in news papers/ technical journals iv) Suppliers list received from plants/ units	TF						
B.	Short list suppliers from the available list, if necessary, based on the following criteria (refer part-2 of format enclosed in Annex) of past performance. i) Approx. value of package ii) Type of package iii) Location of plant/ unit concerned	TF						
C.	Evaluate the short listed supplier (refer part-3 of format enclosed in Annex).	TF						
D.	Prepare a final list of suppliers selected based on evaluation criteria (refer part-4 of format enclosed in Annex) from past performance records.	TF						
E.	Obtain the approval of HOD/ TFL and forward the recommended list to In-charge (PFC) for packages costing more than Rs 1 crore. For packages costing upto Rs 1 crore go to step-G.	TF						
F.	Obtain approval of competent authority as per following guidelines before recommending the names of suppliers to customer: <table border="1" style="width: 100%; border-collapse: collapse;"> <thead> <tr> <th align="center">Package Cost</th> <th align="center">Competent Authority</th> </tr> </thead> <tbody> <tr> <td align="center">Rs 1 to 5 crore</td> <td align="center">CGM</td> </tr> <tr> <td align="center">Above Rs 5 crore</td> <td align="center">ED</td> </tr> </tbody> </table>	Package Cost	Competent Authority	Rs 1 to 5 crore	CGM	Above Rs 5 crore	ED	In-charge (PFC)
Package Cost	Competent Authority							
Rs 1 to 5 crore	CGM							
Above Rs 5 crore	ED							
G.	i) Forward the list of approved suppliers (for package upto Rs 1 crore and for which HOD's approval has been obtained in step E to the customer along with	TF						



	the TS or separately and a copy of the approved list to In-charge (PFC)& TFL for records. ii) Forward the list of approved suppliers for package more than Rs 1 crore and for which approval has been obtained in step F to the customer along with the TS or separately.	In-charge (PFC)
Records to be maintained		
i.	List of recommended suppliers and related papers.	TF

ISSUED & CONTROLLED BY

APPROVED

**(MANAGEMENT
REPRESENTATIVE)**

(EXECUTIVE DIRECTOR)

Annex

(Reference procedure no. P 8.4-21)

FORMAT FOR SELECTION OF SUPPLIERS FOR ISSUE OF LTE

Name of the package:

TS No.:

Type of the package:

PART - 1: SUPPLIERS KNOWN TO BE IN THE FIELD:

PART - 2: CONSIDERING THE PLANT LOCATION, ESTIMATED VALUE OF THE PROJECT AND THE TYPE OF PACKAGE, THE FOLLOWING SUPPLIERS ARE CONSIDERED FOR FURTHER EVALUATION:



Annex
(Reference procedure no. P 8.4-21)

PART - 3: DETAILED EVALUATION OF THE SUPPLIERS:

Sl. No.	Name of the suppliers	Whether registered with concerned plant/ unit	Similar jobs executed with value	Expertise / technical back-up support	Whether agent/ manufacturer	Past performance record w.r.t delivery etc.	Remarks
1.							
2.							
3.							
4.							
5.							
6.							
7.							
8.							
9.							
10.							

Annex

(Reference procedure no. P 8.4-21)

PART - 4: RECOMMENDATION:

Based on the above evaluation, the following parties are proposed to be recommended to the customer for issue of LTE for the package under consideration:

Name/ Signature of TF

Remarks of HOD/ TFL:

Name/ Signature of TFL/ HOD

Remarks of In-charge (PFC), for packages above Rs 1 crore.:

Name/ Signature of In-charge (PFC)

Remarks of approving authority:

Name/ Signature of approving authority



1. **Title:** Internal assignment
2. **Purpose:** To ensure clarity of services required from different sections to meet output requirement
3. **Scope:** All assignments
4. **Overall responsibility:** HOD (LS)/ HOD
5. **Details of sequential activities:**

Sl. No.	Description	Responsibility
A.	Segregate discipline wise scope of assignment among TF.	TFL
B.	Issue internal assignment furnishing all necessary details to concerned HODs in format no. CET-GEN-04 given in Annex (including drawings/ data if required). Note: i) Internal assignments shall be issued for all assignments. ii) Sketches issued alongwith internal assignments may have name/ signature of the concerned engineer with purpose written as 'sketch for internal assignment'. iii) Time schedule for completion of internal assignment should be discussed with the concerned HODs before finalization.	HOD (LS)
C.	Work out detailed scope for the section with TF (can be done internally) and identify the areas where assistance is required from other sections.	HOD
D.	Issue further internal assignment to concerned sections, if required.	HOD
E.	Ensure that all necessary technical details are furnished and clarifications given on queries, as required.	TF
F.	Complete internal assignment and send to HOD (LS)/ HOD (issuing section).	HOD
G.	Follow up with concerned section for completion of internal assignment.	TFL



Records to be maintained		
i.	Copies of internal assignment	TF
ii.	Copies of reply to internal assignment	TF

ISSUED & CONTROLLED BY

APPROVED

**(MANAGEMENT
REPRESENTATIVE)**

(EXECUTIVE DIRECTOR)

INTERNAL ASSIGNMENT

From		To	
Section-	Name-	Section-	Name of TFM concerned
Assignment no.		Issue date	
Title		By when required	
Name of engineer to be contacted for clarifications			

Brief description of the job with all necessary input information:

Action required:

Enclosures:

Name
HOD (Issuing section)

NOTE: The above format will be in use in general cases. However, for certain cases, depending upon the nature of job involved, suitable formats are uploaded in the CET Portal, which are to be used as annexures alongwith the above format.



1. **Title:** Review of assignments
2. **Purpose:** To ensure that assignments are completed as per schedule
3. **Scope:** All assignments
4. **Overall responsibility:** HOD (LS)
5. **Details of sequential activities:**

Sl. No.	Description	Responsibility
A.	Schedule the review of assignment. Note: The review shall be done at least once in a month. If the schedule needs to be extended, same shall be done by HOD (LS)	HOD (LS)
B.	Review as per schedule, status of assignment including time schedule w.r.t activity plan, engineering hours spent against budgeted, identify problem, if any, and find out corrective actions. Fill up details in Format No CET-PFC-03 in PMS. Note: i) Additional reviews may be done by ED and CGM as required. ii) During implementation, progress of work at site, constraints being faced, engg. hrs. of TF of Sub-Centre and necessary corrective actions will be reviewed by HOD (SC) and communicated to HOD (LS) and In-charge (PFC) once every month. iii) Whenever there is no activity of CET in any assignment, review may be suspended after recording the reason in the latest review records. Review shall be resumed as soon as activities are resumed.	HOD (LS)
D.	Maintain review status records in format no. CET-PFC-03 which will be stored in soft/ hard form.	HOD (LS)
E.	Follow up for review as per the schedule and ascertain the review status from HOD (LS)	DO
F.	i) Record schedule of submission of documents and drawings to customer. ii) In case of slippage from due date, intimate TFL/ HOD (LS) through In-charge (PFC). iii) Record actual engineering hours consumed against budgeted engg. hours.	DO DO HOD (LS)



	Monitoring activities	Responsibility
A.	Monitor the schedule of submission of drawings and documents. Note: Schedule fulfillment should be +93%.	HOD(LS)/ In-charge (PFC)
B.	Monitor actual engineering hours consumed against budgeted engg. Hours. Note: Actual engineering hours consumed should be within +9% & -15% of budgeted engineering hours up to submission of R-0 documents.	HOD(LS)
	Records to be maintained	
i.	Assignment Review Status in format no. CET-PFC-03 in PMS	HOD (LS)/ TFL

ISSUED & CONTROLLED BY

APPROVED

(MANAGEMENT
REPRESENTATIVE)

(EXECUTIVE DIRECTOR)

ASSIGNMENT REVIEW STATUS

Assignment no.:	Customer :
Title of Assignment:	
Activity: FR/ AN/ MNP/ DPR/ TS/ Others (pl. indicate):	
Scheduled date of completion of activity:	
TFL :	In-charge (LS):
Date of review:	

List of participants	1. 2. 3.	
Agenda of meeting	1. 2. 3.	
Action taken against the last review meeting points	1. 2. 3.	
Current status of the assignment		
Engg Hrs consumption	Budgeted:	Actual till date:
Future action plan		
Date of next review		

***Note:** Date of monthly review of each assignment to be finalized by HOD (LS) and the above format to be filled in & signed during each monthly review of assignment and to be kept as records.*

Name/ Signature of HOD (LS)
Date:

1. **Title:** Customer supplied products
2. **Purpose:** To take proper care of the customer supplied products
3. **Scope:** All drawings/ documents procured from customer
4. **Overall responsibility:** HOD
5. **Details of sequential activities:**

Sl. No.	Description	Responsibility
A.	Keep record of drawings and documents received from customer in the format given in Annex and store safely. Records may be kept in register/ file/ electronic media.	TF
B.	In case the drawings/ documents are found to be lost/ damaged at any stage, record and intimate to customer.	TF
Records to be maintained		
i.	Records for receipt of customer supplied drawings/ documents in the format given in Annex.	TF

6. **Cross reference to other documents:** Nil

ISSUED & CONTROLLED BY

APPROVED

**(MANAGEMENT
REPRESENTATIVE)**

(EXECUTIVE DIRECTOR)



Format no. CET-GEN-02
(Reference procedure no. P 8.5-24)

RECORD FOR CUSTOMER SUPPLIED PRODUCTS

Assignment No.:

Sl. No.	Description of drawing/ document	Drawing no./ Reference no.	Location of storage	Signature/ Name

Note: This record shall be maintained by TF.



1. **Title:** Internal audit of QMS
2. **Purpose:** To ensure that QMS is effectively implemented and maintained.
3. **Scope:** All chapters/ procedures of CET Quality Manual and CET Procedures Manual
4. **Overall responsibility:** MR
5. **Details of sequential activities:**

Sl. No.	Description	Responsibility
A.	Prepare schedule for internal audit, (as per ISO Format No. CET-GEN-12), get it approved by ED/competent authority and intimate all HODs and internal auditors. Note: Internal audits should be carried out at least twice a year.	BE co-ordinator
B.	Carry out internal audit and prepare audit report.	Internal Auditors
C.	Discuss with HOD about proposed corrective actions and time schedule for implementation. Submit one copy each to concerned HOD and MR/ BE co-ordinator.	Internal Auditors
D.	Take corrective action within schedule and intimate MR/ BE co-ordinator. Note: If observations are such that actions are required to be taken by other sections, auditee will intimate the concerned sections.	HOD
E.	Verify audit observations with respect to corrective actions taken.	MR
F.	Prepare summary of findings and put up to ED. Circulate summary to all CGMs and HODs.	BE co-ordinator
	Records to be maintained	
i.	Schedule for internal audits (CET-GEN-12)	BE co-ordinator
ii.	Internal audit reports	BE co-ordinator
iii.	Analysis of audit findings	BE co-ordinator

ISSUED & CONTROLLED BY

APPROVED

(MANAGEMENT
REPRESENTATIVE)

(EXECUTIVE DIRECTOR)



Format no. CET-GEN-12
(Reference procedure no. P 9.1-25)

INTERNAL AUDIT (IA) OF CET's QMS

CET's QMS INTERNAL AUDIT NO.:	
DATE OF IA:	
NAME OF BE COORDINATOR :	

Sl.No.	SECTION(S)	AUDITOR (Ms./Shri)	DATE OF AUDIT
PART-'A' : I.A. SCHEDULE FOR DEPARTNMENTS AT RANCHI			
1.	BE		
2.	C & C		
3.	C & IT		
4.	C, C & C		
5.	Civil & Strl		
6.	CTE		
7.	Electrical		
8.	I & S		
9.	Mechanical		
10.	PC & A		
11.	PFC		
12.	Raw Materials		
13.	Refractory		
14.	Rolling Mills		
15.	Steel		
16.	Training		
17.	U & S		
PART-'B' : I.A. SCHEDULE FOR SUB-CENTRES			
18.	BSC		
19.	BOSC		
20.	BUSC		
21.	DSC		
22.	RSC		

Note:

1. Detailed schedule and methodology of audit shall be discussed and finalized by concerned auditors in the opening meeting with the concerned HOD.
2. The audit will be carried out in OFFLINE / ONLINE MODE. In case of Online Mode of Audit, computer with audio and video communication facilities must be tested & kept ready prior to the audit. The auditors are requested to consult and check the availability of the same with the HOD of auditee deptt./ sub-centres beforehand.
3. Change of schedule is not permitted. In case audit as per schedule is not possible, then audit shall be completed within **3 days** of scheduled dates. Revised dates shall be mutually agreed between auditor and auditee and intimated to BE positively. **Audit report shall be submitted within 3 days from the date of audit.**

1. **Title:** Customer Satisfaction Index (CSI)
2. **Purpose:** To measure and improve customer satisfaction
3. **Scope:** All customers for whom assignment has been started, in progress or completed during the year
4. **Overall responsibility:** In-charge (PFC)
5. **Details of sequential activities:**

Sl. No.	Description	Responsibility												
A.	Identify the customers from whom feedback will be taken.	In-charge (PFC)/ In-charge (SC)												
B.	Obtain feedback in format no. CET-PFC-05 given in Annex from customer for the product/ services provided during the period. (Customer feedback from each client will be taken from at least 3 different departments/ units provided there are live assignments going on in at least three or more departments/ units in that plant/ unit.)	In-charge (PFC)/ HOD(SC)												
C.	Calculate customer-wise and overall average CSI based on feedback received on the scale of 1 to 10. Grading of average CSI shall be as given below: <table border="1" style="margin: 10px auto; width: 80%;"> <tbody> <tr> <td style="text-align: center;">Excellent</td> <td style="text-align: center;">7.00</td> <td style="text-align: center;">10.00</td> </tr> <tr> <td style="text-align: center;">Good</td> <td style="text-align: center;">6.00</td> <td style="text-align: center;">6.99</td> </tr> <tr> <td style="text-align: center;">Fair</td> <td style="text-align: center;">5.00</td> <td style="text-align: center;">5.99</td> </tr> <tr> <td style="text-align: center;">Area of concern</td> <td style="text-align: center;">Below</td> <td style="text-align: center;">5.00</td> </tr> </tbody> </table> <p>Note: Feedback should be collected at least once a year.</p>	Excellent	7.00	10.00	Good	6.00	6.99	Fair	5.00	5.99	Area of concern	Below	5.00	In-charge (PFC)
Excellent	7.00	10.00												
Good	6.00	6.99												
Fair	5.00	5.99												
Area of concern	Below	5.00												
D.	Prepare final report and put up to ED.	In-charge (PFC)												
E.	If required, discuss with CGMs and HODs concerned including HOD (SC) regarding improvement in ratings for improving CSI in future.	In-charge (PFC)												
F.	Present the findings & data in Steering Committee Meeting.	BE co-ordinator												
6.	Monitoring activities	Responsibility												
A.	Monitor average CSI. Note: Average CSI should not be less than 7.5. However, for individual item of the format value should not be less than 5.0 (five).	In-charge (PFC)												
	Records to be maintained													
i.	Details of feedback	In-charge (PFC)												

ISSUED & CONTROLLED BY

APPROVED

(MANAGEMENT
REPRESENTATIVE)

(EXECUTIVE DIRECTOR)



Format no. CET-PFC-05
(Reference procedure no. P 9.1-26)

CUSTOMER FEEDBACK

1.	Plant/ unit:	
2.	Service provided during the period:	
3.	Assignment No./Name:	

4. Feedback:

(Please tick appropriate box, Highest marks: 10, Lowest marks:1)

Criteria ↓ \ Marks →	10	9	8	7	6	5	4	3	2	1
Compliance of Time Schedule										
Quality of report/Drawings										
Responsiveness										
Co-ordination										
Engineering Assistance										

5. Specific Feedback, if any:

Signature :

Date :

Name, :

Desi. & Deptt. :

Contact No. :

Note:

- Feedback should generally be taken at least once a year.
- This record will be kept by In-charge Projects.

- 1. Title:** Customer complaints and corrective actions for non-conformities
- 2. Purpose:** To ensure that all customer complaints are promptly attended and corrective actions taken for all non-conformities
- 3. Scope:** All customer complaints and non-conformities identified internally or externally
- 4. Overall responsibility:** In-charge (PFC)
- 5. Details of sequential activities:**

Sl. No.	Description	Responsibility
A.	Receive information of non-conformities in products/ services from any of the following sources and communicate to In-charge (PFC): i) Customer's complaints ii) Internal sources Note: In case of Sub-Centre/ unit office, the complaint is to be communicated to In-charge (PFC) in all cases after keeping record in the format no. CET-PFC-04 given in Annex.	HOD
B.	In case of customer complaint send acknowledgement/ interim reply within five days from the date of receipt.	HOD
C.	Receive the complaint from In-charge (PFC) and record in the format no. CET-PFC-04 given in Annex.	DO
D.	Communicate the complaint to HOD (LS)/ TFL with a copy to ED's Secretariat.	In-charge (PFC)
E.	Discuss with the TF/ others, analyses and finalise the necessary corrective action.	TFL
F.	i) Take corrective action to eliminate non-conformity. ii) Communicate to In-charge (PFC) about details of action taken.	TF HOD(LS)
G.	i) Intimate customer about the actions taken on complaints, with copy to HOD (LS), HOD (SC) and ED's Secretariat. ii) Record the actions taken in the format no. CET-PFC-04 given in Annex.	In-charge (PFC) DO
H.	Find out percentage of complaints against number of reports submitted in six months period (generally between Steering Committee/ Management Review Meetings) and present in subsequent Steering	BE Co-ordinator



	Committee Meeting.	
6.	Monitoring activities	Responsibility
A.	Monitor percentage of customer complaints. Note: Customer complaints should be within 0.8 % of the total reports submitted in six months period.	In-charge (PFC)
B.	Monitor response time taken. Note: Interim reply to customer's queries/ letters should be sent within five days from the date of receipt by the concerned section who sends reply.	HOD
	Records to be maintained	
i.	Customer complaint and non-conformity record in proper format no. CET-PFC-04.	DO

ISSUED & CONTROLLED BY

APPROVED

**(MANAGEMENT
REPRESENTATIVE)**

(EXECUTIVE DIRECTOR)

Format no. CET-PFC-04
(Reference procedure no. P 8.7-27)

CUSTOMER COMPLAINT AND NON-CONFORMITY RECORD

Sl No.	Assignment No.	Details of complaint/ non-conformity	Details of correction/ corrective action	Details of preventive action

Note: This record shall be maintained in register/ file/ electronic media by DO for Ranchi office and by HOD (SC)/ designated employee at Sub-Centres.

- 1. Title:** Preventive actions
- 2. Purpose:** To ensure identification of potential non-conformities, their causes and to prevent their occurrence.
- 3. Scope:** All identified potential non-conformities.
- 4. Overall responsibility:** MR
- 5. Details of sequential activities:**

Sl. No.	Description	Responsibility
A.	i) Identify potential non-conformities from following sources: <ul style="list-style-type: none"> • Assignment review • Customer feedback • Audit results • Any other source ii) Identify the causes of potential non-conformities and suggest preventive actions. Discuss with concerned HOD and inform to BE co-ordinator.	All employees
B.	Receive and analyse information about potential non-conformities.	BE co-ordinator
C.	Discuss potential non-conformities, causes and required preventive actions with MR.	BE co-ordinator
D.	Discuss potential non-conformities and required preventive actions in Steering Committee Meeting.	MR
E.	Communicate preventive actions to all concerned.	BE co-ordinator
F.	Take following actions to prevent occurrence of potential non-conformities: <ol style="list-style-type: none"> i) Verify Design Sheets and Design Summary Sheets ii) Verify for completeness of report. iii) Carry out design review (presentation) of reports. iv) Verify TS in format CET-GEN-09 v) Verify OS in format CET-GEN-05 vi) Verify MNP in format CET-GEN-10 vii) Check and approve drawings viii) Conduct assignment review. ix) Any other preventive action as per step C 	Designated engineer TFL TFL/ HOD (LS) Designated engineer TFL/ HOD (LS) Designated QP HOD/ Designated engineer HOD/ HOD (LS) HOD
G.	If required, follow up for implementation of preventive	MR



	action.	
	Records to be maintained	
i.	Verification records of Design Sheets and Design Summary Sheets in soft form	Engineer concerned
ii.	Records of Design Review (presentation) and approval of reports	DO
iii.	Verification records of TS in format no. CET-GEN-09	TFL
iv.	Verification records of OS in format no. CET-GEN-05	Engineer concerned
v.	Verification records of MNP in format CET-GEN-10	Designated QP
vi.	Assignment review records	HOD/ HOD (LS)
vii.	Record notes of Steering Committee Meeting	BE co-ordinator

ISSUED & CONTROLLED BY

APPROVED

**(MANAGEMENT
REPRESENTATIVE)**

(EXECUTIVE DIRECTOR)

- 1. Title:** Preparation of draft technical contract and facilitating signing of technical contract
- 2. Purpose:** To provide guidelines for preparation of draft technical contract and facilitating signing of contract between customer and contractor
- 3. Scope:** All the Stage-II approved projects for which CET is the consultant
- 4. Overall responsibility:** CGM (LS)
- 5. Details of sequential activities:**

Sl. No.	Description	Responsibility
A.	Receive request from customer for preparation of draft technical contract after placement of LOA/ LOI/ Work order on contractor. Note: In case of single package, PL will be same as TFL and HOD (PL) will be same as HOD (LS).	TFL/ PL
B.	Prepare draft technical contract document and circulate to all TFMs. Basis of draft contract will be TS floated with NIT and MOM during tender discussion.	TFL/ PL
C.	Vet the draft technical contract document and incorporate respective portions in the draft. Return back to TFL/ PL.	All TFMs
D.	i. After compilation, get reviewed by all TFMs and incorporate modifications, if any. Keep record of review. (Resp: TFL / PL) ii. Send the finalized draft technical contract to HOD(PL)/HOD(LS) along with record of review.	TFL/ PL
E.	Send finalized draft technical contract to customer with a request to check and forward to contractor for their examination/ comments/ acceptance alongwith copies to HOD (LS), HOD(SC), In-charge(PL), In-charge (Proj) & respective CGMs for information	HOD (PL)
F.	Review the comments received, if any, from customer/ contractor. Incorporate the acceptable comments in the draft technical contract and reply to customer/ contractor suitably regarding the comments which are not acceptable. Finalize the draft technical contract with the acceptable comments. Send the above final draft contract to customer with a request to forward a copy	HOD (PL) & PL



	to contractor.	
G.	All TFMs to read the finalized draft contract and put their signature on each page of the contract.	All TFMs
H.	On invitation from the customer, nominate competent engineers to participate in the discussions between contractor & customer for finalization of technical contract.	CGM (LS)
I.	Based on the discussion, if any further change is proposed in the draft contract document submitted earlier to customer by CET as mentioned at Sl. No. "F" above, seek approval of CGM (LS) for the changes. After approval, finalize contract document alongwith customer & contractor.	All engineers nominated for contract signing
J.	After compliance of step I. above, if requested by the customer, sign the technical contract alongwith customer and contractor.	TFL/ PL and/or as nominated by CGM (LS) for contract signing - TFMs to sign alongwith TFL in their respective areas. TFL to sign on all pages.
K.	Keep a copy of contract document for record.	TFL

ISSUED & CONTROLLED BY

APPROVED

**(MANAGEMENT
REPRESENTATIVE)**

(EXECUTIVE DIRECTOR)

- 1) **Title** : Procedure to examine change order requests of customer for change in contract elements **(Part-1)**
- 2) **Purpose** : Provide guidelines to examine change order requests of customer for change in contract elements
- 3) **Scope** : To provide technical justification/ tenability in line with contract or whether work is required to be done through separate contract
- 4) **Overall responsibility** : In-charge (PL)
- 5) **Details of sequential activities:**

Sl. no.	Description	Responsibility
5-1)	On receipt of request from customer for change in contract element: i) Ensure relevant formats of “Procedure issued by Project Directorate, SAIL CO, in May, 2024 & its amendments/ revisions if any” have been complied (Copy annexed) Send the request from customer to In-charge (PFC)	PL/ TFL/ Sub-centre
5-2)	Re-ensure compliance of “Procedure issued by Project Directorate, SAIL CO, in May, 2024 & its amendments/ revisions if any” in the request from customer	In-charge (PFC)
Steps to be followed in case change order request pertains to package of LS (specific to Domain of LS or Domain of TFM’s Section)		
5-3)	Send request to In-charge (LS)	In-charge (PFC)
5-4)	Send request to TFL/ In-charge (Domain) (as per the case) with intimation to CGM (LS)/ CGM (Domain)	In-charge (LS)
5-5)	Examine change order request to provide technical justification/ tenability in line with the contract or Whether work is required to be done through separate contract. Submit views to In-charge (LS)/ In-charge (Domain) (as per the case)	TFL/ TFM (Domain)
5-6)	Evaluate views, ensure incorporation of changes (if any) and submit updated views to CGM (LS)/ CGM (Domain)	In-charge (LS)/ In-charge (Domain)
5-7)	If the case pertains to LS Review & finalize views with In-charge (LS) & TFL and submit to In-charge (PFC) with intimation to In-charge (LS)	CGM (LS)
5-8)	If the case pertains to TFM-Domain Review & finalize views with In-charge & TFM (Domain)	CGM (Domain)



	and send finalized views to CGM (LS)	
5-9)	Send finalized views of CGM (Domain) to In-charge (PFC) with intimation to In-charge (LS)	CGM (LS)
5-10)	Submit finalized views to CGM (Projects)	In-charge (PFC)
5-11)	Approve/ reject views with prior intimation to ED (CET) and send to In-charge (PFC) with intimation to CGM (LS) and CGM (Domain) (as applicable)	CGM (Projects)
5-12)	Intimate views of CET to the customer through (Sub-centre at ISPs)/ directly (other Units) and intimate all concerned Above activities to be complied within 7 days of receipt of request from customer	In-charge(PFC)
Steps to be followed in case change order request pertains to package with TFM as PL (specific to Domain of PL or Domain of TFM's Section)		
5-13)	Send request to In-charge (PL) with intimation to CGM (PL), CGM (LS), In-charge (LS)	In-charge (PFC)
5-14)	Send request to PL/ In-charge (Domain) (as per the case) with intimation to CGM (PL)/ CGM (Domain)	In-charge (PL)
5-15)	Examine change order request to provide technical justification/ tenability in line with the contract or Whether work is required to be done through separate contract. Submit views to In-charge (PL)/ In-charge (Domain) (as per the case)	PL/ TFM (Domain)
5-16)	Evaluate views, ensure incorporation of changes (if any) and submit updated views to CGM (PL)/ CGM (Domain) (as per the case)	In-charge (PL)/ In-charge (Domain)
5-17)	If the case pertains to PL Review & finalize views with In-charge (PL) & PL and send to In-charge (PFC) with intimation to In-charge (PL)	CGM (PL)
5-18)	If the case pertains to TFM-Domain Review & finalize views with In-charge & TFM (Domain) and send finalized views to CGM (PL)	CGM (Domain)
5-19)	Send finalized views of CGM (Domain) to In-charge (PFC) with intimation to In-charge (PL)	CGM (PL)
5-20)	Submit finalized views to CGM (Projects)	In-charge (PFC)
5-21)	Approve/ reject views with prior intimation to ED (CET) and send to In-charge (PFC) with intimation to CGM (LS) and CGM (PL)/ CGM (Domain) (as applicable)	CGM (Projects)



5-22)	Intimate views of CET to the customer through (Sub-centre at ISPs)/ directly (other Units) and intimate all concerned Note: Above activities to be completed within seven days of receipt of request from customer	In-charge (PFC)
-------	--	-----------------

ISSUED, CONTROLLED & APPROVED BY
(EXECUTIVE DIRECTOR)



- 1) **Title** : Procedure to examine change order requests of customer for change in contract elements **(Part-2)**
- 2) **Purpose** : Provide guidelines to examine:
- Technical part of the change order proposal for giving views on applicability/ reasonability of the proposal
 - Giving views on engineering estimate/ budgetary offer of contractor
- 3) **Scope** : To examine technical part of the change order proposal for giving views on applicability/ reasonability of the proposal and on engineering estimate/ budgetary offer of contractor
- 4) **Overall responsibility** : In-charge (PL)
- 5) **Details of sequential activities** :

Sl. no.	Description	Responsibility
5-1)	On receipt of request from customer to examine technical part of the change order proposal for giving views on applicability/ reasonability of the proposal and on engineering estimate/ budgetary offer of contractor, send the document to In-charge (PFC)	PL/ TFL/ Sub-centre
5-2)	Send request to In-charge (LS)/ In-charge (PL)/ In-charge (Domain) as applicable with intimation to CGM (LS), CGM (PL)/ CGM (Domain) & In-charge (LS)	In-charge (PFC)
5-3)	Send request to TFL/ PL/ TFM (Domain) as applicable with intimation to CGM (LS)/ CGM (PL)/CGM (Domain)	In-charge (LS)/ In-charge (PL)/ In-charge (Domain)
5-4)	Examine technical part of the change order proposal, for giving views on applicability/ reasonability of the proposal, work-out basis/ inputs for generating views on engineering estimate/ budgetary offer of contractor. Submit the view/ inputs to respective In-charge	TFL/ PL/ TFM (Domain) with assistance of TFM-CTE
5-5)	If the case pertains to TFM-Domain Evaluate views, incorporate changes (if any) and submit updated views to In-charge CTE for generating views on engineering estimate/ budgetary offer of contractor	In-charge (Domain)
5-6)	Review & generate updated views on engineering estimate/ budgetary offer of contractor. Organize cost committee (as per requirement) for review/ finalization of views. Submit finalized views to In-charge (domain) with a copy to CGM (Domain).	In-Charge (CTE)
5-7)	Review & finalize views with In-charge & TFM (Domain) and forward finalized views to CGM (PL)	CGM (Domain)
5-8)	Send finalized views to In-charge (PFC) with intimation to In-charge (PL)	CGM (PL)

5-9)	If the case pertains to PL Evaluate views, incorporate changes (if any) and submit updated views to In-charge CTE for generating views on engineering estimate/ budgetary offer of contractor	In-charge (PL)
5-10)	Review & generate updated views on engineering estimate/ budgetary offer of contractor. Organize cost committee (as per requirement) for review/ finalization of views. Submit finalized views to In-charge (PL) with a copy to CGM (PL).	In-Charge (CTE)
5-11)	Review & finalize views with In-charge (PL) & PL and send to In-charge (PFC) with intimation to In-charge (PL)	CGM (PL)
5-12)	If the case pertains to LS Evaluate views, incorporate changes (if any) and submit updated views to In-charge CTE for generating views on engineering estimate/ budgetary offer of contractor	In-charge (LS)
5-13)	Review & generate updated views on engineering estimate/ budgetary offer of contractor. Organize cost committee (as per requirement) for review/ finalization of views. Submit finalized views to In-charge (LS) with a copy to CGM (LS).	In-Charge (CTE)
5-14)	Review & finalize views with In-charge (LS) & TFL and send final views to Incharge (PFC) with intimation to In-charge (LS)	CGM (LS)
5-15)	Submit finalized views to CGM (Projects) for review/ approval	In-charge (PFC)
5-16)	Approve views/ modified (if required) views, with prior intimation to ED (CET) and send to In-charge (PFC) with intimation to CGM (LS) and CGM (PL)/ CGM (Domain), as applicable	CGM (Projects)
5-17)	Intimate views of CET to customer through (Sub-centre at ISPs)/ directly (other Units) and intimate all concerned Note: Above activities to be completed within seven days of receipt of request from customer	In-charge (PFC)

ISSUED, CONTROLLED & APPROVED BY

(EXECUTIVE DIRECTOR)

ANNEX
(Reference Procedure No. P 8.5-30)**STEEL AUTHORITY OF INDIA LIMITED**

- 1 **Subject** : Procedure for executing change in facilities
- 2 **Reference** : SBD /GCC clause no. 41 for TK cases and relevant clause of GCC for NTK cases
- 3 **Objective** : To address the proposal for execution of extra items/Change Orders/additional scope of work
- 4 **Scope** : During the execution of the contract, if there are any proposals for any change, modification, addition or deletion to, in or from the facilities (hereinafter called "Change"), provided that such change falls within the general scope of the Facilities and does not constitute unrelated work and that it is technically practicable, taking into account both the state of advancement of the facilities and the technical compatibility of change envisaged with the nature of the facilities as specified in the contract.

No change made necessary because of any default of the contractor in the performance of its obligations under the contract shall be deemed to be change, and such change shall not result in any adjustment of the Contract price or the time of completion.

5. Procedure for issuance of Change Order

Sl. No.	Job Description	Responsibility	Time frame
1.	Request from employer or contractor for change	Shop/Project Zone /Contractor	As per need (well in advance)
2.	Refer the proposal to the Consultant for their opinion regarding technical justification, scope of contract agreement etc.	Project Manager	Within 7 days from the receipt of change proposal
3.	Consultant to provide the technical Justification/Tenability in line with the contract or whether the work is required to be done through separate contract.	Consultant	1 week
4.	After receiving Consultants opinion, to obtain In-Principle approval from Competent Authority to accept the change proposal. In case of exigencies, Executing Agency may propose "Go Ahead" permission to start the work pending all formalities in concurrence of ED (Works), with the approval of ED (Projects).	Project Manager /Shop owner/ CGM (Projects)	1 Week



5.	After obtaining In-Principle approval, Employer shall send to the contractor a “Request for change proposal” in prescribed format (Annexure-1).	Project Manager/Head of Project Commercial	3 days
6.	Contractor to submit Change Proposal in prescribed format (Annexure- 2) It will be in two parts in separate sealed envelopes : Part-I : Technical Details and un-priced schedule of estimate Part-II: Estimated amount . The pricing as far as practicable be calculated in accordance with the rates and prices included in the contract. Items for which the price is not included in the contract price schedule, specific rates with complete break-up of prices shall be provided.	Contractor /Project (Comm) / Project Manager	7 Days
7.	After receiving Change Proposal from Contractor, send to the Consultant for examination and to get comments on engineering estimate/budgetary offer of contractor.	Project Manager	7 days
8.	Consultant shall examine the technical part of the proposal and confirm the applicability/reasonability of change order Consultant shall also provide their views/comments on Engg estimate/ Budgetary offer.	Consultant/Project Manager	Within 7 days
9.	Examination/Recommendation by Change order Committee. Change order Committee comprises of i. CGM (Projects) - Chairman ii. Project Owner iii. Project Commercial/MM –Projects iv. Project Manager v. Projects- Finance vi. Consultant-Invitee Member	Change order Committee/Project Manager	10 days



	<p><u>Change Order Committee scope:</u></p> <ul style="list-style-type: none"> ➤ Scrutinize and finalize relevant commercial conditions (Viz. price variation, base date, execution period and its effect on overall completion time, Insurance value, payment terms etc.) w.r.t. change order ➤ Evaluate the prices offered ➤ Negotiate with the contractor, if required ➤ Examine the reasonability of the final price received and furnish recommendations. 		
10.	<p>After receiving recommendation of change order Committee, Initiate for approval of CA as per DOP</p> <ul style="list-style-type: none"> • For value of change order/extra items <Rs. 10 Crore and within 10% of contract value approval by ED (Projects) • For all other cases >Rs. 10 Crore approval by DIC 	MM-Project, /Proj (Comm),/Project Manager .	<ul style="list-style-type: none"> • Process within within 3 days of receipt of recommendation • Approval by CA within 7 days
11.	<p>After approval of Competent Authority, issue the change order in the prescribed format (Annexure-3) to contractor</p>	MM-Project/Project (Comm)/Project Manager	Within 3 days of receipt of approval/ budget approval.
12.	<p><u>In disagreement cases</u> If the contractor and the employer cannot reach agreement on price for change, an equitable adjustment of the time for completion, or any other matters identified in the Change proposal, the Employer may nevertheless instruct the contractor to proceed with the change by issue of a "Pending Agreement Change Order" in the format at Annexure-4 with the approval of the DIC.</p>	Project (Comm)/MM-Projects/Project Manager	1 week after change order Committee recommendation
12 (a).	<p>Upon receipt of pending change order, the contractor shall immediately proceed with effecting the change covered by such order.</p>		1 Week



12 (b.)	Employer and contractor shall attempt to reach agreement within 120 days And on reaching such agreement the contractor to furnish " Application for change Proposal " in the format at Annexure-5 as agreed. Subsequently, the amendment to the contract will be issued for incorporating the change with the approval of CA.	Contractor/Project Manager/Project (Comm)/MM-Projects	120 days
12 (c.)	If the parties cannot reach the agreement within 120 days from the date of issue of Pending agreement change order, then the matter may be referred to for the Conciliation/Arbitration as per Clause no. 6 of GCC by MM-Project/ Project Commercial through the concerned Project Manager	MM-Project/Project (Comm)/MM-Projects/Project Manager	120 days.

6. If the Employer decides not to proceed with the change for whatever reason, it shall, within 14 days, notify the Contractor accordingly.

Footnote

- In case of any conflict between the clauses above and clauses of SBD as appearing in the respective contracts, the SBD clauses will prevail.

Enclosure:

- Annexure-1 : Request for Change Proposal
- Annexure-2 : Change Proposal (Technical)
- Annexure-3: Change Order
- Annexure-4 : Pending Agreement Change Order
- Annexure-5: Application for Change proposal

Annexure - 1

Request for Change Proposal

< EMPLOYER'S LETTERHEAD >

Date: _____

To < Contractor's Name & Address >

Attention: < Name & Title >

Contract Name : < Contract Name >
Contract Number : < Contract Number >

Dear Sirs,

With reference to the captioned Contract, you are requested to prepare and submit a Change Proposal for the Change noted below in accordance with the following instructions within < Number > days of the date of this letter < or on or before <date> >.

1. Title of Change : < Title >
2. Change Request [No. / Rev.] : < Request Number/ Revision >
3. Originator of Change : Employer : < Name >
Contractor (by Application for Change Proposal No. < Number >)
4. Brief Description of Change : < Description >
5. Facilities and/or Item No. of equipment related to the requested Change : < Description >
6. Reference drawings and/or technical documents for the request of Change :
< Drawing Number/ Document Number > < Description >
7. Detailed conditions or special requirements on the requested Change : < Description >
8. General Terms & Conditions :
 - a) Please submit your estimate to us showing what effect the requested Change will have on the Contract Price
 - b) Your estimate shall include your claim for the additional time, if any, for completion of the requested Change.
 - c) If you have any opinion negative to the adoption of the requested Change in connection with the conformability to the other provisions of the Contract or the safety of the Plant or Facilities, please inform us of your opinion in your proposal of revised provisions.
 - d) Any increase or decrease in the work of the Contractor relating to the services of its personnel shall be calculated.

page-5

e) You shall not proceed with the execution of the work for the requested Change until we have accepted and confirmed the amount and nature in writing.

(Employer's Name)

(Signature)

(Name of Signatory)

(Title of Signatory)

page-6

Annexure - 2

Change Proposal(Technical)

< CONTRACTOR'S LETTERHEAD >

Date: _____

To < Employer's Name & Address >

Attention: < Name & Title >

Contract Name : < Contract Name >
Contract Number : < Contract Number >

Dear Sirs,

In response to your Change Proposal No. < Number >, we hereby submit our proposal as follows:

1. Title of Change : < Name >
2. Change Proposal [No. / Rev.] : < Proposal Number/ Revision >
3. Originator of Change : Employer : < Name >
Contractor : < Name >
4. Brief Description of Change : < Description >
5. Reasons of Change : < Reason >
6. Facilities and/or Item No. of Equipment related to the requested Change : < Facilities >
7. Reference drawings and/or technical documents for the request of Change :
< Drawing Number/ Document Number > < Description >
8. Estimate of increase/decrease to the Contract Price resulting from Change Proposal (Amount to be indicated in separate sealed envelope. In this Technical part Contractor will mark "Quoted" or "Q" under Amount:

Sl	Description	Amount
a	Direct Material	
b	Major construction equipment	
c	Direct field labour (Total _____ Hrs.)	
d	Sub-Contracts	
e	Indirect material & labour	

page-7

Sl	Description	Amount
f	Site Supervision	
g	Head Office technical staff salaries	
	Process engineer __hrs @ ____Rs/hr	
	Project engineer __hrs @ ____Rs/hr	
	Equipment __hrs @ ____Rs/hr	
	Procurement __hrs @ ____Rs/hr	
	Sub total	
h	Extraordinary costs(computer, travel, etc.)	
i	Fee for general administration (% of items)	
j	Taxes & Customs Duties	
	Total lumpsum cost of Change Proposal [Sum of Items (a) to (j)]	

9. Additional time for Completion required due to Change Proposal :
10. Effect on the Functional Guarantees :
11. Effect on the other terms and conditions of the Contract :
12. Validity of this Proposal: Within < Number >days after receipt of this Proposal by the Employer
13. Other Terms & Conditions of this Change Proposal:
- a) You are requested to notify us of your acceptance, comments or rejection of this detailed Change Proposal within < Number >days from receipt of this Proposal
- b) The amount of any increase and/or decrease shall be taken into account in the adjustment of the Contract Price.

(Contractor's Name)

(Signature)

(Name of Signatory)

(Title of Signatory)

page-8

Annexure - 3

Change Order

< EMPLOYER'S LETTERHEAD >

Date: _____

To < Contractor's Name & Address >

Attention: < Name & Title >

Contract Name : < Contract Name >
Contract Number : < Contract Number >

Dear Sirs,

We approve the Change Order for the work specified in the Change Proposal (No. < Number >), and agree to adjust the Contract Price, Time for Completion and/or other conditions of the Contract in accordance with GCC Clause no.41 of the General Conditions of Contract.

1. Title of Change : < Title >
2. Change Request [No. / Rev.] : < Request Number/ Revision >
3. Originator of Change : Employer : < Name >
Contractor : < Name >
4. Authorised Price :
Ref. No.: < Number > Date: < Date >
Foreign Currency Portion: < Amount > plus Local Currency Portion: < Amount >
5. Adjustment of time for completion :
None Increase < Number > days Decrease < Number > days
6. Other effects, if any :

Authorised by: _____ Date: _____
(Employer)

Accepted by: _____ Date: _____
(Contractor)

page-9

Annexure - 4

Pending Agreement Change Order

< EMPLOYER'S LETTERHEAD >

Date: _____

To < Contractor's Name & Address >

Attention: < Name & Title >

Contract Name : < Contract Name >

Contract Number : < Contract Number >

Dear Sirs,

We instruct you to carry out the work in the Change Order detailed below in accordance with GCC Clause no.41 of the General Conditions of Contract, pending finalisation of change order

1. Title of Change : < Title >
2. Employer's Request for Change Proposal [No. / Rev.] : < Request Number/ Revision > Date: < Date >
3. Contractor's Change Proposal [No. / Rev.] : < Request Number/ Revision > Date: < Date >
4. Brief Description of Change : < Description >
5. Facilities and/or Item No. of Equipment related to the requested Change : < Facilities >
6. Reference drawings and/or technical documents for the requested Change :
< Drawing Number/ Document Number > < Description >
7. Adjustment of time for completion :
None Increase < Number > days Decrease < Number > days
8. Other change in the Contract terms :
9. Other terms and conditions :

(Employer's Name)

(Signature)

(Name of Signatory)

(Title of Signatory)

page-10

Annexure - 5

Application for Change Proposal

< CONTRACTOR'S LETTERHEAD >

Date: _____

To < Employer's Name & Address >

Attention: < Name & Title >

Contract Name : < Contract Name >

Contract Number : < Contract Number >

Dear Sirs,

We hereby propose that the below mentioned work be treated as a Change in the Facilities.

1. Title of Change : < Name >
2. Application for Change Proposal [No. / Rev.] : < Proposal Number/ Revision dt.:[Date].>
3. Brief Description of Change : < Description >
4. Reasons of Change : < Reason >
5. Order of Magnitude Estimation (in the currencies of the Contract):
6. Scheduled Impact of Change :
7. Effect of Functional Guarantees, if any :
8. Appendix

(Contractor's Name)

(Signature)

(Name of Signatory)

(Title of Signatory)

Page-11

- 1. Title:** Preparation & approval of Eligibility Criteria (EC)
- 2. Purpose:** To facilitate wider participation of competent bidders in the tendering process.
- 3. Scope:** Eligibility Criteria (EC) for TS of each package
- 4. Overall responsibility:** In-charge (LS/PL)
- 5. Details of sequential activities:**

Sl. No.	Description	Responsibility
A.	i) EC is to be prepared for Open Tender Enquiry (OTE). ii) TS & EC are to be prepared simultaneously by TFL/PL. iii) Prepare bidder's profile based on available/collected information about probable bidders (may take reference of bidders participated in similar type of projects) iv) Prepare draft EC as per standard template (available in CET Portal)/ refer earlier EC for similar projects and as per requirement(s) of the project. v) Check if consortium bidding allowed or not (refer relevant clause of FR) vi) Submit the draft EC & bidder's profile to In-charge for further processing for approval	TFL/PL
B.	Vet the draft EC & referred bidder's profile and get required corrections, (if any) and forward to respective CGM (LS).	In-charge(LS/PL)
C.	Vet the draft EC & referred bidder's profile and get required corrections, (if any) and forward to In-charge (PFC).	CGM(LS)
D.	In case of Sub Centre as Lead Section, CGM (SC) will follow the above process and forward the same to In-charge(PFC).	CGM(SC)
E.	i) Vetting of draft EC on the basis of bidder's profile by PFC ii) Incorporation of observations/ finalization (if applicable) of draft EC in consultation with TFL/PL/	In-charge(PFC)/ (DO)

	In-charge(LS) with information to CGM(LS). iii) Process for approval of EC by CGM (Projects). Bidder's profile to be submitted for reference.	
F.	Approve the EC and send the same alongwith referred bidder's profile to In-charge(PFC)	CGM (Projects)
G.	i) Make pdf copy of approved EC and submit the same & referred bidder's profile to client through SC. ii) Send a copy of the approval records alongwith issued EC & bidders profile to TFL and/or PL for their record. iii) Upload the issued EC in central database.	In-charge(PFC)/ (DO)
6.	Monitoring activities	Responsibility
i.	Ensure Bidder's profile is submitted alongwith EC for approval.	TFL
	Records to be maintained	
i.	Records of referred bidder's profile and approved EC	TFL/In-charge(LS)/PL

ISSUED, CONTROLLED & APPROVED BY

(EXECUTIVE DIRECTOR)

- 1. Title:** Preparation & approval of Capital Cost Estimate (CE)
- 2. Purpose:** To ensure that capital Cost is prepared and submitted within stipulated time.
- 3. Scope:** Capital Cost Estimate
- 4. Overall responsibility:** In-charge (CTE)
- 5. Details of sequential activities:**

Sl. No.	Description	Responsibility
A.	Send the request for preparation of capital cost estimate with compiled BoQ to In-charge(CTE)/TFM(CTE) through In-charge(LS). The compiled BoQ should include basis of rates considered like cost data base/BQ/PO/ engineering estimate alongwith related documents, if any.	In-charge(LS) / TFL
B.	i) Check, review with TFL/TFM, if required and Prepare Capital Cost Estimate and send to In-charge(LS) / TFL for final review. ii) Get the Capital Cost Estimate checked and reviewed by TFL with TFM wrt covering of complete scope of the assignments for finalization of CE.	In-charge (CTE)/ TFM(CTE)
C.	i) Check for any changes / observations and finalise the Capital Cost Estimate. ii) Organize Cost Review Committee Meeting for project costing more than Rs. 30 crore OR as per management decision. iii) Prepare MoM of Cost Review Committee Meeting. iv) Get consent of Cost Review Committee meeting members on the MoM. v) For project value upto Rs.30 crore OR as per management decision, obtain approval of CGM(Projects)	TFM(CTE)
D.	Prepare the financial write-up / Cost Sheet (as applicable) for the relevant document and send the same to TFL.	In-charge(CTE)/ TFM(CTE)
6	Records to be maintained	



i.	Records of MoM of Cost Committee meeting	In-charge(CTE)/ TFM(CTE)
ii.	Records of Capital Cost Estimate	In-charge(CTE)/ TFM(CTE)

ISSUED, CONTROLLED & APPROVED BY

(EXECUTIVE DIRECTOR)

1. **Title:** Preparation & approval of Package Cost
2. **Purpose:** To ensure timely preparation and submission of package cost
3. **Scope:** Package Cost
4. **Overall responsibility:** In-charge (CTE)
5. **Details of sequential activities:**

Sl.No.	Description	Responsibility
A.	Procedure for package cost of 'Soil Investigation & Survey (SIS)' and 'Underground Mapping (UGM) Work:	
	i) Request from plant for package cost received by SC/TFL/PL/TFM. If request received by persons other than TFL/PL, forward the same to TFL/PL and In-charge (PFC)	In-charge (SC)/ TFL/PL/TFM
	ii) Prepare and submit schedule of items alongwith pre-approved item wise rates to CTE	PL
	iii) Prepare package cost for 'Soil Investigation & Survey' and 'Underground mapping' work	TFM(CTE)
	iv) Vet/ scrutinize package cost, convert into a password protected pdf document and issue directly to ED(Project)/In-charge (Projects) of Plant/units through email with intimation to Plant Sub-Centre In-charge, In-charge(PFC), PL, TFL and CGM(Projects). v) Send password in email separately on receipt of request from plant/units (to the designated id as indicated in the request letter).	In-charge (CTE)
B.	Procedure for package cost other than SIS and UGM packages	
	i) Request from plant for package cost received by SC/TFL/PL/TFM. If request received by persons other than TFL/PL, same to be forwarded to TFL/PL and In-charge (PFC).	In-charge (SC)/ TFL/PL/TFM
	ii) Update BoQ in consultation with Task Force, taking outcome of tender discussions into consideration. iii) Compile BoQ inclusive of basis of estimate like cost data base/BQ/PO/engineering estimate alongwith related documents, if any.	TFL/PL/In- charge(LS)



	iv) Send updated BoQ alongwith details of eligible bidders, copy of Stage-I approval and change in scope of work, if any, wrt Stage-I approval to CTE with due concurrence of CGM(LS)	In-charge(LS)
	v) Check BoQ and get clarifications, if any	In-charge (CTE)
	vi) Prepare draft package cost	TFM(CTE)
	vii) For project value upto Rs.30 crore, Obtain approval of CGM(Projects) and follow from Step XII.	In-charge (CTE)
	viii) For project costing more than Rs. 30 crore OR as per management decision, Organize Cost Review Committee Meeting	
	ix) Deliberate and finalize package cost	Cost Review Committee
	x) Prepare MoM of Cost Review Committee Meeting xi) Obtain signature of Cost Review Committee members on MoM and circulate to members xii) Convert package cost into a password protected pdf document and issue directly to ED(Project)/In-charge (Projects) of Plant/units through email with intimation to Plant Sub-Centre In-charge, In-charge(PFC), PL, TFL and CGM(Projects) xiii) Send password in email separately on receipt of request from plant (to the designated id as indicated in the request letter)	In-charge (CTE)/ TFM(CTE)
6	Records to be maintained	
i.	Keep Records of MoM of Cost Committee meeting	TFM/In-charge(CTE)
ii.	Keep Records of approved package cost	TFM/In-charge(CTE)

ISSUED, CONTROLLED & APPROVED BY

(EXECUTIVE DIRECTOR)